

BONENG



**C/F/K/S齿
轮马达使用
手册**

**C/F/K/S
Gearmotor
Use Manual**

01/2024

中文

EN

目录

重要提示	01
1 安全说明	02
2 技术说明	02
2.1 铭牌说明	02
2.2 型号表示方法	03
2.3 齿轮马达的噪声水平	05
2.4 温升	05
2.5 注意事项	05
3 安装与拆卸	06
3.1 安装前的注意事项	06
3.2 准备工作	06
3.3 齿轮马达的整机安装	06
3.4 齿轮马达空心轴的安装	07
3.5 齿轮马达空心轴的拆卸	08
3.6 扭力臂的安装	09
3.7 输入部分和马达间的安装	09
3.8 齿轮马达的拆卸	10
4 安装方位	10
4.1 安装方位的说明	10
4.2 安装方位页面的说明	10
5 润滑/冷却/加热	17
5.1 润滑油的选择	17
5.2 润滑油的注油量	17
5.3 润滑油的更换	20
5.4 加热	20
5.5 逆止机构	20
6 使用	20
6.1 润滑油添加	20
6.2 设备检查	20
6.3 起动	20

7 检查与维护	21
7.1 定期检查与维护	21
7.2 检查与维护的周期	21
7.3 检查与维护的注意事项	21
8 故障处理	22
9 马达概述	22
9.1 说明	22
9.2 产品适用范围	22
10 一般要求	23
10.1 起动	23
11 使用说明	24
11.1 运行环境	24
11.2 安全要素	24
11.3 遵守规则	24
12 管理	24
12.1 储存	24
12.2 运输	24
13 电气联接	24
13.1 概述	24
13.2 接线指示图(标配)	25
14 维护	27
14.1 概论	27
14.2 轴承润滑	27
14.3 制动器的维护	27
14.4 变频马达的维护特点	28
15 售后服务	33

重要提示

在安装操作过程中, 请注意本手册中的安全提示和警告提示!



使用建议和有用的信息



有害情况:
可能产生的后果: 损坏传动装置和环境



- ◆ 遵守本手册的规定可以让装置无故障运行, 同时也满足质量缺陷索赔的要求, 因此在使用传动装置进行工作之前, 请您先阅读本手册;
- ◆ 本手册包含重要的安装维护提示, 请将手册保管在靠近设备的位置, 以便安装维护参阅。

齿轮马达

1 安全说明

安全说明主要涉及齿轮马达的使用。当使用齿轮马达时，请注意手册中的相关安全提示！

- ◆使用手册为本公司所供齿轮马达的有机组成部分。
- ◆齿轮马达的安装、操作、维护和修理人员均需认真阅读本手册并遵守其中的规定。
- ◆严格遵循手册中的规定是实现产品无故障运行和履行任何质量保证要求的必要条件。
- ◆在遵循手册规定的前提下还要注意：
 - 相关安全和事故防范的国家(地区)规定；
 - 相关设备的特别规定和要求；
 - 设备装置上的安全警告和安全标志牌。
- ◆下列情况会导致人身伤害和财产损失：
 - 使用不当；
 - 安装或操作失误；
 - 违反规定拆除必要的防护罩或机壳。
- ◆若因违反本手册的规定而造成的任何损伤或停机，本公司概不负责。
- ◆为不断追求技术进步，我们保留对其进行修改的权力。通过不断改进，将在保持基本特性的基础上，有利于进一步提高其使用性能和工作安全性。

2 技术说明

2.1 铭牌说明

BONENG	
Type	
n ₂	RPM
P ₁ kW	T ₂ N·m
n ₁ RPM	i
Oil	Wt. kg
NO.	Date

- ①产品型号
- ②输出转速
(直联马达时才有)
- ③额定输入功率 kW
(直联马达时指马达功率)
- ④额定输出扭矩 N·m
- ⑤额定输入转速 RPM
(直联马达时是指马达转速)
- ⑥公称减速比
- ⑦润滑油粘度
- ⑧重量
- ⑨产品编号
- ⑩出厂日期

◆铭牌上的数据十分重要，请仔细阅读，并保持其整洁，当需要服务时，请提供铭牌上的产品编号、使用时间及故障类型。

2.2 型号表示方法

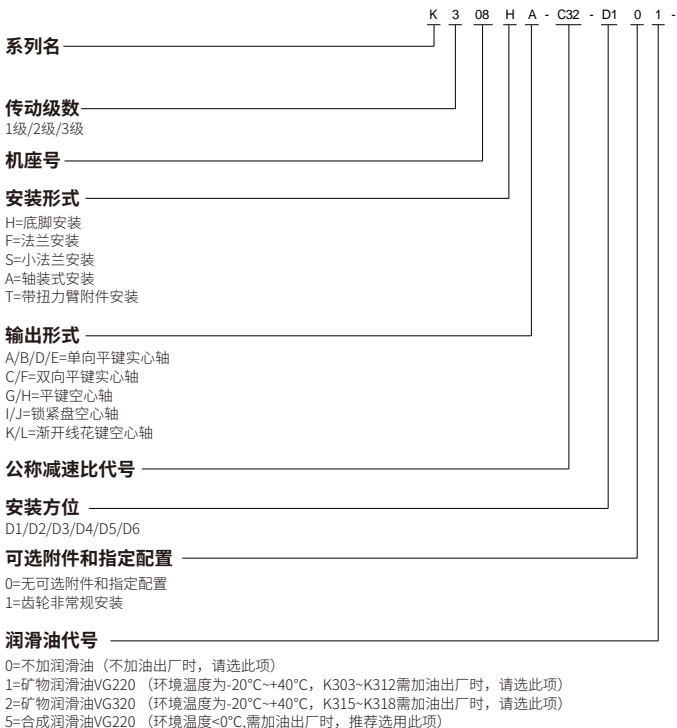

注¹⁾ 马达系列/机座号/极数/功率代号

功率 kW	MH/MP/MU	功率 kW	MH/MP/MU	功率 kW	MA	功率 kW	MA
0.12	MH063M4A12AL MP063M4A12AL MU063M4A12AL	4	MH112L4B40AC MP112L4B40AC MU132S4B40AC	0.12	MA063M4A12AL	4	MA112L4B40AC
0.18	MH063M4A18AL MP063M4A18AL MU063M4A18AL	5.5	MH132S4B55AC MP132M4B55AC MU132M4B55AC	0.18	MA063M4A18AL	5.5	MA132L4B55AC
0.25	MH071M4A25AL MP071M4A25AL MU071M4A25AL	7.5	MH132M4B75AC MP132L4B75AC MU160M4B75AC	0.25	MA071M4A25AL	7.5	MA132L4B75AC
0.37	MH071M4A37AL MP071M4A37AL MU071M4A37AL	11	MH160S4C11AC MP160M4C11AC MU160L4C11AC	0.37	MA071M4A37AL	11	MA160M4C11AC
0.55	MH080M4A55AL MP080M4A55AL MU080M4A55AL	15	MH160M4C15AC MP160L4C15AC MU180M4C15AC	0.55	MA080M4A55AL	15	MA160L4C15AC
0.75	MH080M4A75AL MP080M4A75AL MU090S4A75AL	18.5	MH180M4C18AC MP180M4C18AC MU180L4C18AC	0.75	MA080M4A75AL	18.5	MA180M4C18AC
1.1	MH090S4B11AL MP090S4B11AL MU090L4B11AL	22	MH180L4C22AC MP180L4C22AC MU200L4C22AC	1.1	MA090M4B11AL	22	MA180L4C22AC
1.5	MH090S4B15AL MP090M4B15AL MU100L4B15AL	30	MH200M4C30AC MP200M4C30AC MU225S4C30AC	1.5	MA090M4B15AL	30	MA200M4C30AC
2.2	MH100M4B22AL MP100M4B22AL MU100L4B22AL	37	MH225M4C37AC MP225M4C37AC MU225M4C37AC	2.2	MA100M4B22AL	37	MA225M4C37AC
3	MH100M4B30AL MP100M4B30AL MU112M4B30AC	45	MH225M4C45AC MP225M4C45AC MU250M4C45AC	3	MA100M4B30AL	45	MA225M4C45AC
/	/	55	MH250M4C55AC MP250M4C55AC MU280S4C55AC	/	/	55	MA250M4C55AC
/	/	75	MH280S4C75AC MP280S4C75AC MU280M4C75AC	/	/	75	MA280S4C75AC
/	/	90	MH280M4C90AC MP280M4C90AC MU280M4C90AC	/	/	90	MA280M4C90AC



◆配输入法兰或输入轴型号示例: K308HA-C32-D101-AE3

◆配输入法兰和马达型号示例: K308HA-C32-D101-AP132-MH132S4B55FC3-A0N10-011

◆组合型号示例: K308HA/C205-D28-D100-MH080M4A75AL1-A0N00-011

注: MA系列 (NEMA能效三相交流异步马达) 可选极数代号4, 频率/电压代号6,8,G,H,J,K, 制动器代号A,D,G,K。

2.3 齿轮马达的噪声水平

- ◆噪声符合相关的国家标准,行业标准及企业标准。
- ◆噪声的检测根据声强法进行,距声源处(所检测表面噪声区域)1m的距离检测。
- ◆噪声水平是指齿轮马达在良好工况条件下正常运行,在标牌上规定的额定输入转速 n_1 、额定输入功率 P_1 条件下工作时,检测得到的噪声水平。如果给出不同的参数,则选择最高转速和最大功率值。
- ◆由于所采用的检测技术使重复测量无法得到最终结果,则应采用本公司试验台上得到的检测结果。
- ◆齿轮马达的A级全噪声声功率级不应大于80dB(A)。

2.4 温升

- ◆齿轮马达运转时产生的温升环境温度为40°C时,油池最高温度不超过85°C。
- ◆齿轮马达运转时允许的润滑油温度范围大致如下:
 - 矿物油约-10°C~+90°C(瞬间+100°C)
 - 合成油约-20°C~+100°C(瞬间+110°C)

2.5 注意事项(下述注意事项与齿轮马达的使用有关):

- ◆在户外安装时应避免阳光直射,一定要避免热力集中影响齿轮马达的正常性能。
- ◆一定不能用高压清理设备清洁齿轮马达。
- ◆对齿轮马达所进行检修、保养、维护、安装都必须在齿轮马达不工作的情况下进行。
- ◆在齿轮马达上不得进行焊接工作,也不得用作焊接工作的接地点。焊接会造成精密齿轮和轴承不可修复的损坏。
- ◆如果在齿轮马达的运行过程中发现了任何异常现象(例如过热或者不正常的噪声等),应该立即关断驱动装置。
- ◆凡是旋转的零部件必须配备合适的防护罩以防止人员的意外接触,例如联轴器,液力偶合器,齿轮,驱动皮带轮等。
- ◆一定要遵守齿轮马达上所附加的说明,例如铭牌、指示方向的箭头等。这些铭牌和标记上面不得有灰尘和油漆。
- ◆在组装或者拆卸工作中损坏了的螺栓一定要用同等强度和类型的新螺栓更换。
- ◆本公司对不合理使用联轴器、私自对齿轮马达进行修改,以及使用非本公司零部件的情况,所造成的不良后果不在‘三包’服务之内。
- ◆根据齿轮马达的操作条件,齿轮马达的表面、润滑油和零部件可能会达到相当高的温度,小心烫伤!
- ◆当更换润滑油的时候,要谨慎小心,不要被热油烫伤。
- ◆齿轮马达应该放置在不振动的干燥木制基座上并遮盖好。当储存齿轮马达和任何单独零部件的时候一定要做好防锈措施,以免生锈,储存时不得将齿轮马达叠放在一起。
- ◆除订货合同中另外有所规定,否则齿轮马达不得储存或工作在强酸、强碱、低温、高温和重度的空气污染、潮湿以及具有化学物品的场所。
- ◆在搬运齿轮马达时,一定要特别小心,防止轴端被撞击,因为这样将有可能造成齿轮马达的损坏。在吊运齿轮马达时,不得将吊环螺钉安装在轴端处的螺纹上。
- ◆配件一定要从BONENG公司购买。

3 安装与拆卸

3.1 安装前的注意事项



- ◆ 确认齿轮马达完好无损(在运输或储存过程中未损坏);
- ◆ 确认现场环境条件与铭牌内容相符;
- ◆ 标准齿轮马达使用环境温度为: $-20^{\circ}\text{C} \sim +40^{\circ}\text{C}$; 无油、酸、有害气体、蒸汽、放射性物质等;
- ◆ 若齿轮马达储存时间在一年以上, 轴承内润滑剂的使用寿命将缩短。



- ◆ 在户外安装时应该避免阳光直射, 一定要避免热力集中影响齿轮马达的正常性能;
- ◆ 特殊形式齿轮马达: 是根据环境条件配置的;
- ◆ 在进行规划阶段就应该预留足够的空间进行维护保养和修理工作。

3.2 准备工作

- ◆ 彻底清除输出输入轴和法兰表面的防腐剂、污物等; 注意不要让溶剂浸入并损坏油封;
- ◆ 工具/材料的准备: 一组扳手、扭矩扳手、装配夹具、输入和输出紧固装置、润滑剂(防锈油)、密封螺栓的介质(螺纹锁固剂)。

3.3 齿轮马达的整机安装

- ◆ 齿轮马达只能按规定的安装位置安装在平的、减振的、刚性好的、抗扭的支撑结构上; 同时也需充分考虑即使加上最大载荷不至于改变装配好后各部件的位置。
- ◆ 应使用安装在箱体上的吊环进行吊装;



注: 禁止使用轴端螺纹安装吊环后做为起吊点。

- ◆ 底座式安装应校准中心高; 联轴器联接时应校准两轴的同轴度; 柔性联轴器时浮动量不超过联轴器的允许范围; 刚性连接时保证各安装联接的形位公差; 长轴联接还要考虑轴的足够刚度。

底座式安装时应校准中心高:

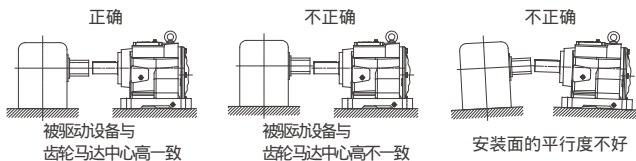

- ◆ 安装联轴器时应该校正下列各点:

a) 最大和最小间距

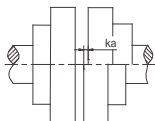

b) 角度偏差

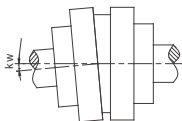

c) 轴线偏差

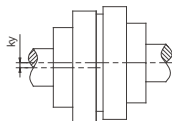

◆法兰式安装,凸肩(或凹肩)应配合良好,以免错位;

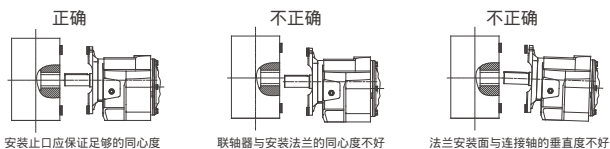

在齿轮马达的输入或输出轴上安装联轴器、皮带轮、齿轮、链轮等时,必须符合以下要求:

◆使用合适升降装置利用轴端螺纹孔,压入连接件,严禁直接使用锤子敲击。

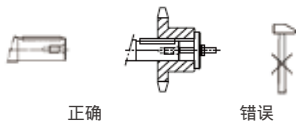

◆皮带轮、链轮、搅拌式还需考虑径向力,如图示。

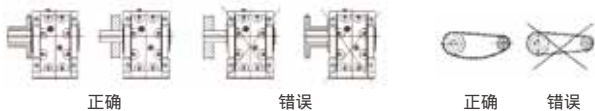

3.4 齿轮马达空心轴的安装

◆齿轮马达空心轴与被驱动设备的实心轴连接时,应清理干净并涂防锈油(空心轴一定要精密对中)。除了图中所示的螺母和螺杆的方法安装以外,还可以使用其它类型的装置安装,例如液压提升装置等。

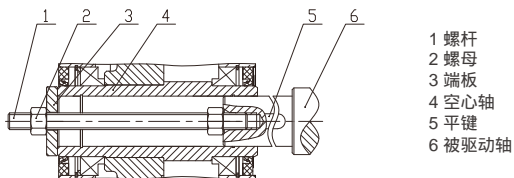

◆当齿轮马达空心轴配置锁紧盘时,应先空心轴上套上锁紧盘,再按上述方法完成被驱动设备的驱动轴的安装,在安装被驱动设备的驱动轴之前不要拧紧锁紧盘上的紧固螺栓。



→所供货的锁紧盘是可直接安装的,在首次受力之前一定不能拆卸下来。
→安装锁紧盘前,要确保空心轴孔和被驱动设备的驱动轴在锁紧盘区域不能有润滑油。

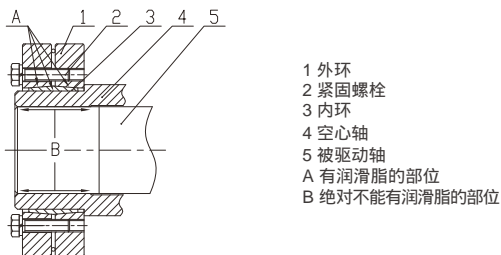

◆拧紧锁紧盘上的螺栓时,严禁按相邻顺序逐个拧紧,应按锁紧盘安装要求,按等边三角形顺序逐次拧紧紧固螺栓,每次循环拧紧过程中,每个螺栓只能拧紧螺丝的1/4圈。

◆安装螺栓一般情况下采用8.8级,如果有高温或者振动冲击等情况,请在螺纹连接处作好防松措施。各个紧固螺栓的拧紧扭矩见下表:

螺栓大小 (mm)	预紧力矩 (N·m)	螺栓大小 (mm)	预紧力矩 (N·m)
M6	15	M30	2000
M8	36	M36	3560
M10	72	M42	5720
M12	123	M48	8640
M16	295	M56	13850
M20	580	M64	14300
M24	1000	M72	20800

3.5 齿轮马达空心轴的拆卸

空心轴的拆卸

根据现场实际上可以使用的设备,可以用在端板上的螺杆、中心螺杆或者液压提升装置将减速机从被驱动设备的驱动轴上脱下来。空心轴的每个端面都配备了2个螺丝孔可以拧入固定端板的螺栓。

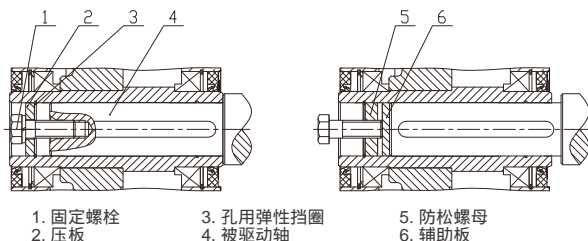

注:
辅助板不在供货范围内。(空心轴端螺纹孔的分布和大小请参照BONENG公司技术图纸)

配置了锁紧盘的齿轮马达空心轴拆卸时,锁紧盘松开过程与紧固的方向相反,拆掉锁紧盘后再按上述方法完成被驱动设备驱动轴的拆卸。
拆卸锁紧盘时应注意:
→拆卸时严禁按照相邻的顺序松开螺栓。
→锁紧盘外环与内环不能分离时,可将几个螺栓拧入拆卸螺丝,将内环和外环分开。

3.6 扭力臂的安装

◆扭力臂安装,空心轴与工作轴应配合良好,工作轴的浮动或设备振动应小于弹性块允许的范围,力臂应固定并锁紧。

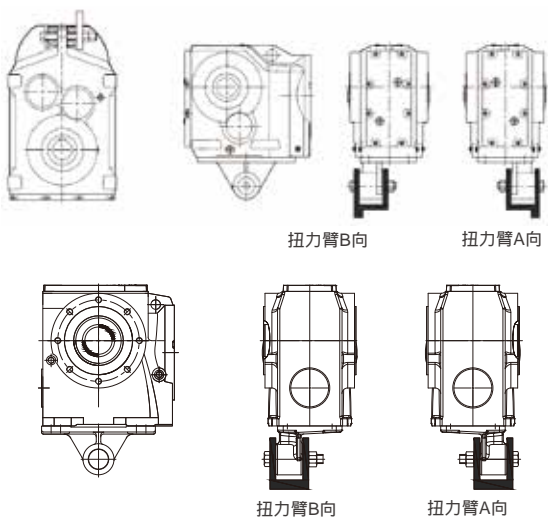

3.7 输入部分(AE或AP)和马达间的安装

◆清洁马达轴和马达法兰及联轴器的表面;除去马达轴上的键,更换新键;将半联轴器加热至100°C左右,然后套入马达轴或AE轴,分别装至马达或AE轴台阶处;将键和联轴器半体用紧定螺钉紧固于马达轴或AE轴上;将马达装到联轴器装置上,要确保两个半联轴器相互啮合(参见下图)。弹性块不可以加热。

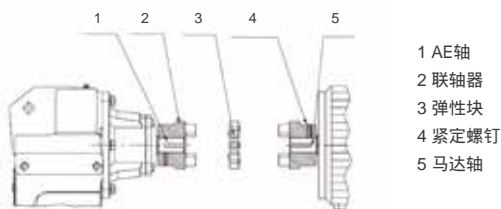

3.8 齿轮马达的拆卸

- ◆根据现场实际可使用的设备,将齿轮马达从安装平台上拆卸下来,拆卸时注意不要对输出轴表面造成损伤。

4 安装方位

4.1 安装方位的说明

- ◆齿轮马达的具体安装方位及选型可参见BONENG公司产品选型手册。

4.2 安装方位页面的说明

- ◆齿轮马达的安装方位页面中使用的图形符号及其含义:

图形符号		含 义	
		通气帽	进油孔
		油 镜	
		放油孔	

C斜齿齿轮马达的安装方位
C103H~C110H

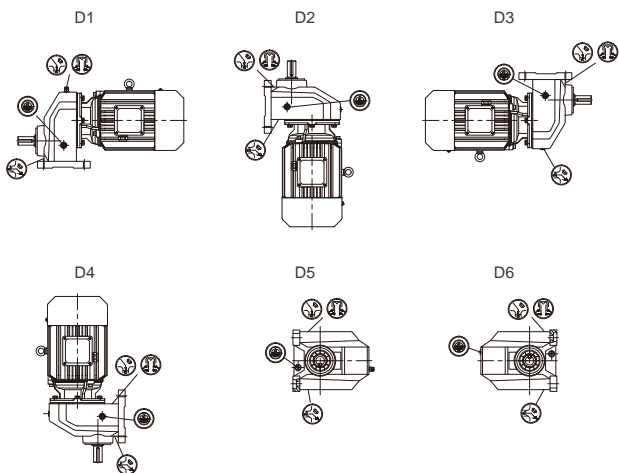

C103F~C110F

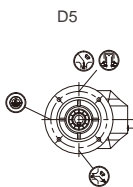
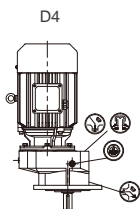
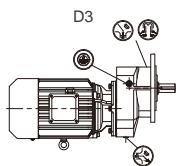
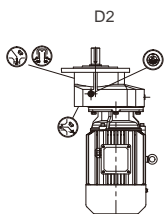
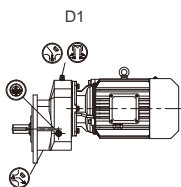

中文

C203H~C216H
C303H~C316H

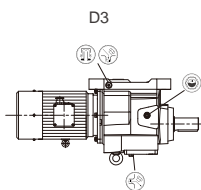
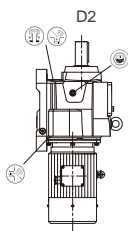
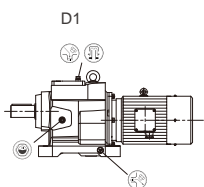

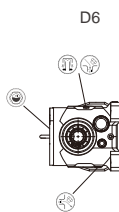
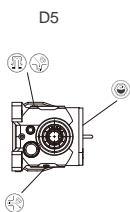
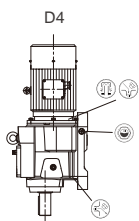

C203F/S~C216F/S
C303F/S~C316F/S

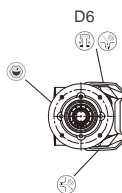
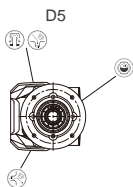
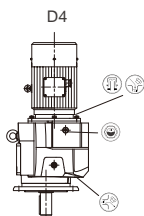
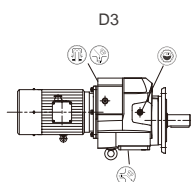
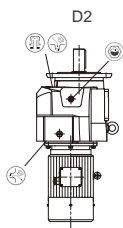
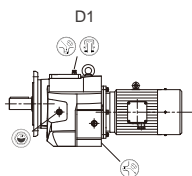

F202H/F/S/A/T~F215H/F/S/A/T
F302H/F/S/A/T~F315H/F/S/A/T

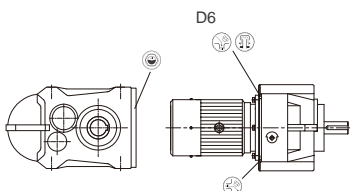
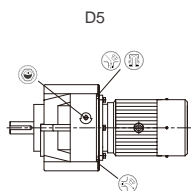
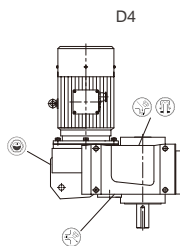
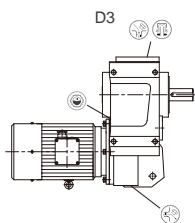
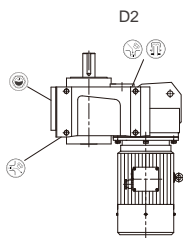
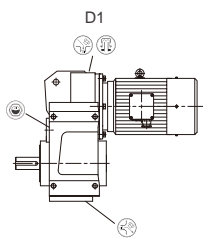

K斜齿-锥齿齿轮马达的安装方位
K303H/F/S/A-K315H/F/S/A,K316H/F-K318H/F

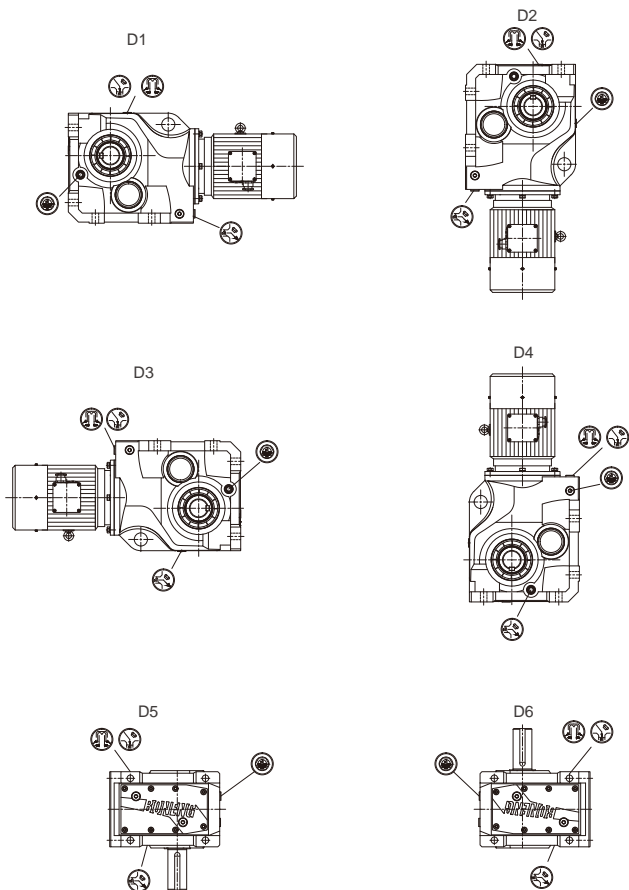

S斜齿-蜗轮齿轮马达的安装方位
 S103H/F/S/A - S209H/F/S/A , S210F/S/A - S212F/S/A

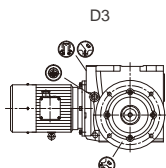
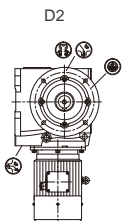
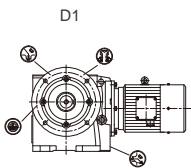
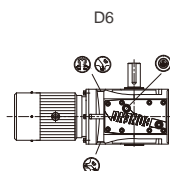
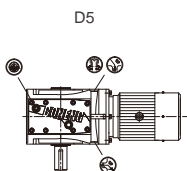
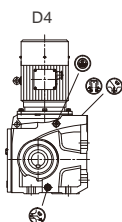
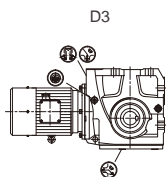
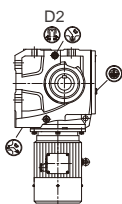
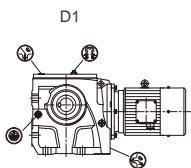

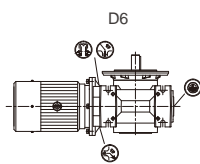
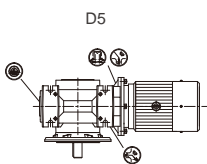
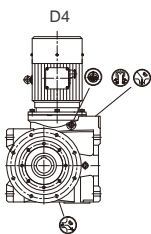
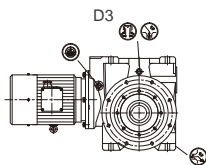
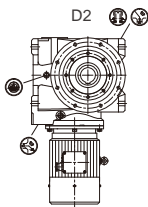
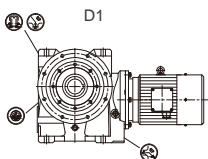
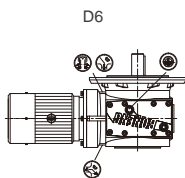
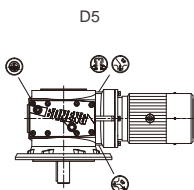
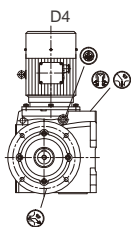

5 润滑/冷却/加热

5.1 润滑油的选择

◆在相同粘度等级和类型的前提下，您可以自由地选择国际知名品牌的润滑油。如需改变推荐的粘度等级

敬请垂询。

◆下表列出了博能使用润滑油的选择。

型号	润滑油牌号 (符合ISO粘度等级)	环境温度
C200/C201	000#极压锂基润滑脂 VG220	-20°C ~ +40°C
C300/C301		
C103~C110		
C203~C216		
C303~C316		
F202~F215		
F302~F315		
K303~K312	VG320	
K315~K318	VG680	
S203~S212	VG680	



◎环境温度低于-10°C时必须使用合成油。

◎为确保产品的使用寿命，实际使用中推荐使用合成油。

◎使用环境温度超过上述范围时，请咨询BONENG公司技术部门。

5.2 润滑油的注油量

◆本注油量为建议值。根据齿轮马达级数和速比的不同，相应加油量也不同。请注意油镜作为加油量多少的指示，油位必须在油镜的中间位置。

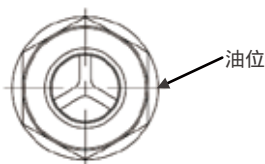

◆下表列出了对于安装方位相应的润滑油注油量建议值。

5.2.1 C系列注油量

油量表 (L)						
安装方位 型号	D1	D2	D3	D4	D5	D6
C103	0.52	0.36	0.45	0.6	0.36	0.36
C104	0.7	0.45	0.6	0.8	0.45	0.45
C106	0.8	0.5	0.7	0.9	0.5	0.5
C107	1.6	1	1.6	2	1	1
C108	2.5	1.8	2.7	3.1	1.6	1.6
C109	3.5	2.5	3.7	4.3	2.2	2.2
C110	6.2	4.1	7.7	8.5	4.1	4.1
C200 C300	0.2	0.2	0.2	0.3	0.2	0.2
C201 C301	0.4	0.4	0.4	0.5	0.4	0.4
C203 C303	0.4	1	1.1	1.2	0.9	1.1
C204 C304	1	1.1	1.1	1.1	1.8	1.7
C205 C305	1.5	1.7	1.8	1.8	2.6	2.5
C206 C306	2	2.3	2.4	2.5	3.3	3.2
C207 C307	2	2.9	2.8	3.1	3.6	3.5
C208 C308	3.9	6.4	5.5	6	7.8	7.5
C209 C309	7.8	9.7	9.5	10.1	13.1	12.8
C210 C310	11	16.8	14.8	16.1	20	18.8
C212 C312	14.8	21.7	20.7	21.8	27	26.4
C213 C313	18.6	26.6	26.6	27.4	34	33.9
C214 C314	28.7	39	35.5	38.9	52	48.5
C216 C316	49.5	64	62	69	89	88

5.2.2F系列注油量

		油量表(L)					
安装方位 型号	D01	D02	D03	D04	D05	D06	
F202 F302	0.7	0.9	1	1	0.9	0.8	
F203 F303	1.2	1.4	1.3	1.5	1.3	1.1	
F204 F304	1.8	2.1	2.2	2.3	2.2	1.9	
F205 F305	2.1	2.8	2.5	2.9	2.4	2.3	
F206 F306	3.1	3.9	4.1	4.2	3.9	3.3	
F207 F307	5.8	7.8	7.6	8.6	7.2	6.8	
F208 F308	10.9	14.8	13.7	14.7	13.2	11.3	
F209 F309	20	28	27	26	24	21	
F210 F310	25	37	35	36	32	27	
F212 F312	43	65	58	66	56	59	
F215 F315	75	125	101	116	97	84	

5.2.3K系列注油量

		油量表(L)					
安装方位 型号	D1	D2	D3	D4	D5	D6	
K303	0.8	0.8	0.7	0.9	0.8	0.8	
K304	1.2	1.1	1.2	1.6	1.3	1.3	
K305	2.2	1.7	1.2	2.5	2.1	2.1	
K306	2.2	1.6	1.6	2.6	1.9	1.9	
K307	2.9	3.9	3.1	5.4	4.5	4.5	
K308	5.2	6.6	8	10	8	8	
K309	11	12	15	19	15	15	
K310	17	21	25	33	25	24	
K312	28	37	41	55	41	40	
K315	50	61	68	90	72	71	
K316	77	84	109	143	114	110	
K318	103	113	155	202	158	158	

5.2.4S系列注油量

油量表(L)						
安装方位 型号	D01	D02	D03	D04	D05	D06
S203	0.3	0.5	0.6	0.7	0.5	0.5
S204	0.5	1.1	1.1	1.4	1.2	1.2
S205	0.6	1.4	1.2	1.9	1.7	1.7
S206	1.2	2.6	3.7	3.8	3.2	3.2
S207	2.3	5.0	7.0	7.8	5.9	5.9
S208	4.6	9.7	12.5	14.4	10.9	10.9
S209	8.9	18.0	22.6	28.3	21.6	21.6
S210	12.5	45.6	37.8	45.6	25.4	25.4
S212	22.0	80.4	63.6	80.4	42.8	42.8

注：在环境温度-10°C~+40°C时，S系列润滑油牌号为VG680(ISO粘度等级)。

5.3 润滑油的更换

◆要用和原来的润滑油同一牌号、同一厂家的润滑油。更换润滑油品种时，要用润滑油将齿轮马达箱体里面的沉积物、金属颗粒和残留的润滑油都冲洗干净。

5.4 加热

◆对标准齿轮马达：使用环境温度-20°C~+40°C，当环境温度低于-10°C时需预热或空载启动，当齿轮马达温度超过-10°C时允许加载运行。

5.5 逆止机构

◆带逆止器的齿轮马达：在安装或启动前，一定要检查传动装置的旋转方向，为防止错误的旋转方向，必要时请向技术部门咨询。逆止器为免维护。

6 使用

6.1 润滑油添加

◆本公司产品一般都未带润滑油出厂，在设备运行前请先按使用说明书加润滑油。



在标记有该符号的位置上将通气帽拧出，给齿轮马达加入润滑油。

6.2 设备检查

- ◆检查油面高度。
- ◆配备了止回装置的齿轮马达，检查马达接线是否正确。
- ◆检查轴封是否有效。
- ◆检查旋转的零部件是否与其它零件接触。

6.3 起动

- ◆检查自由状态下转动方向是否正确（同时监听轴转动时是否有异常研磨噪声）。
- ◆运行检查时要保证轴上没有输出元件，同时开启相关的监测和保护设备。
- ◆无论什么时候，只要怀疑出现了不正常的运行现象（例如 温升、噪声、振动等异常），应立即关掉马达，并查明原因。
- ◆必要时与BONENG公司联系。

7 检查与维护

7.1 定期检查与维护

◆用户要定期对齿轮马达进行维护和保养，要定期检查润滑油的使用状态，定期清理通气帽、风扇、冷却盘管和齿轮马达表面的灰尘和异物，保持齿轮马达清洁，保证齿轮马达的正常运行。

7.2 检查与维护的周期

检查油温	每日
检查齿轮马达的不正常的噪声	每日
检查油面高度	每月
检查齿轮马达的漏油	每月
检验油中的水分	在400工作小时后,至少每年一次
在起动之后的首次换油	在400工作小时后
其后的换油	每5000工作小时,至少每年一次
清理通气帽	每3个月
清理齿轮马达箱体	和换油同时进行
检查紧固螺栓的紧固程度	第一次换油后,其后每隔一次换油
对于齿轮马达的全面检查	大约每2年和换油同时进行

7.3 检查与维护的注意事项

- ◆切断电源，防止触电，等待齿轮马达冷却。
- ◆油位的检查：油位必须在油镜的中间位置。
- ◆油的检查：移去油塞，取油样，检查油的粘度指数；如果油明显浑浊，建议尽快更换。
- ◆油的更换：
 - 不同的润滑剂禁止相互混合使用。
 - 冷却后油的粘度会增大,放油困难,换油时齿轮箱应保持温热。
 - 在油塞下面放一个接油盘,拆下油塞/通气帽,将油全部排除后装上油塞。
 - 注入同牌号的新油,油量应与安装方位一致(见铭牌);若牌号不同则向我司售后服务咨询。
 - 在油镜处检查油位，装上通气帽。

8 故障处理

故障	原因	措施
齿轮马达的噪声变化	紧固件松动了	将螺栓/螺母拧紧到规定的扭矩。 更换损坏了的螺栓/螺母。
	齿轮马达的齿轮发生了损坏	和售后服务部联系。 → 检查所有的齿轮，更换损坏了的零件。
	轴承间隙过大	和售后服务部联系。 → 调整轴承的间隙。
	轴承损坏	和售后服务部联系。 → 更换损坏的轴承。
工作温度过高	箱体里面的油面过高或过低	检查油面的高度，如果有必要的话，调整。
	油过于陈旧	和售后服务部联系。 检查上一次换油的时间，如果有必要的话就更换。
	油受到严重污染	和售后服务部联系。 → 换油
轴承处的振幅升高	轴承损坏	和售后服务部联系。 → 查阅操作人员在振动测量中所获得的数据。 → 检查并按需更换轴承。
	齿轮损坏	和售后服务部联系。 → 检查并按需更换齿轮。
齿轮马达漏油	箱体盖或者连接处的密封不良	检查密封和连接处，如果有必要的话，更换新的。将连接处密封好。
	径向轴封环失效	和售后服务部联系。 → 换新的径向密封。
油中有水	油中有杂物	用试管检查油的状态是否有水分存在。 实验室分析油
	齿轮马达受到机器间的通风过来的凉空气而产生凝霜	用合适的保温材料将齿轮箱保护起来。 关闭空气的出口或者在结构上改变其方向。

9 马达概述

9.1 说明

◆ 本说明书为我公司马达的随机文件。其中介绍了马达起动、储运、安装的要求和注意事项，以及使用、维护马达的要求、方法和注意事项，使用维护人员必须认真阅读此说明书。认真审阅马达上的铭牌、标牌、警示牌等。使用单位应对操作人员进行专业培训后，方能上岗作业。

⚠ 注意:

为保证设备安全和正确的安装、操作和维护，请务必遵守本说明书的相关条款。负责安装操作或维护设备的人员应注意相关说明，忽视说明将会使质保失效。

9.2 产品适用范围

◆ 本说明书适用于博能各标准系列及其所派生的各种系列马达（防爆系列马达除外）。机座中心高：56-280。（对一些特殊应用场合或有特殊设计考虑的型号马达还需参阅其它特别的指导说明）。

10 一般要求

10.1 起动

10.1.1 收货检验

- ◆收货后，立即检验马达有无外部损伤，检验所有的铭牌数据，尤其是电压的连接方式(Y或 Δ)。
- ◆用手旋转载轴，检测马达空转情况，如果马达装有锁定装置，注意将其打开。
- ◆带制动器马达，应通电看其制动器能否动作，带手柄制动器，应扳动手柄，检查手动释放性能。

10.1.2 绝缘性能检测

- ◆马达初次使用之前，绕组有可能受潮，都要测量其绝缘阻值；对双绕组多速马达要分别测量两套绕组的绝缘电阻。

 注意:测量后绕组要立即放电，避免电击。

- ◆绕组被海水浸泡后一般要重绕。

10.1.3 直接起动、Y/ Δ 起动及变频起动

- ◆标准单速马达的接线盒一般有6个接线螺栓和至少1个接地螺栓。
- ◆马达通电之前，必须按规定要求可靠接地，不能接零代替接地。
- ◆电压连接方式在铭牌上有标注。

◎直接起动

绕组可以采用Y或 Δ 接法，例如660VY，380V Δ 分别表示660V为Y接法，380V为 Δ 接法。

◎Y/ Δ 起动

- 电源电压必须等于 Δ 接法马达的额定电压。
- 拆下接线板上所有的接线片，按Y/ Δ 起动装置接线，妥善连接到马达六个接线柱上，并能从起动初期的Y连接跳到启动完成的 Δ 接。
- 双速马达和其他特种马达的电源接法必须依照接线盒内的接线图说明。

◎变频起动

- 按照变频器的使用说明书，对变频器正确地实施接线并进行通电前的检查。检查无误后，先不接马达，对变频器的各项参数逐一设定、调整。在确认变频器运转无问题后，再联接马达。
- 给出“接通”指令后，若马达不转，请先检查一下变频器，设置参数是否正确，若马达还不转，请再检查马达的接线和负载情况。
- 对IC416冷却方式的变频马达，强冷风机启动正常运行后，再启动马达，并注意观察马达、传动装置、生产机械及变频器面板的显示数据，若有异常现象应立即停机，查明故障并排除之后，方可重新启动。

10.1.4 接线柱和旋转方向

- ◆从马达的驱动端观察转轴，其旋转方向为顺时针。
- ◆换接电源线中的任意两相就可以改变马达的旋转方向。

11 使用说明

11.1 运行环境

- ◆ 马达用于工业生产。
- ◆ 正常的环境温度在-15°C到+40°C之间，海拔不高于1000m。

11.2 安全要素

- ◆ 马达应由熟悉相关安全要求的专业人员安装和接线。
- ◆ 安装时必须有安全装置以防止事故发生，安装的位置也必须符合规定。

11.3 遵守规则

- ◆ 马达不能用于加速和超载运行。
- ◆ 一些有特殊设计考虑的马达需要特别的指导说明。

12 管理

12.1 储存

- ◆ 所有马达都应保存在室内，要求干燥，防震，防尘的环境。
- ◆ 无保护层的马达表面(轴伸端部和法兰)应该采取防锈措施。
- ◆ 建议定期检查马达，用手转动转轴，防止润滑脂流失或其它问题。
- ◆ 如果装有抗凝露加热器，最好使用。

12.2 运输

- ◆ 马达在运输时需要安装锁紧装置。

13 电气联接

13.1 概述:

- ◆ 马达顶部的接线盒允许旋转，可按要求选择出线方向。
- ◆ 没有电缆进入的进线口必须封闭。
- ◆ 除了主绕组和接地端的接线，接线盒内还可包括热敏电阻，加热带，热敏开关或PT100电阻元件及制动器的接线部件。
- ◆ 对于装有电磁制动器的马达用户自供电源时应保证马达电源与制动器电源同步切换。
- ◆ 冷却方式为IC416的变频马达需安装轴流风机。轴流风机配有专用的接线盒。风机马达应与相应的电源电压相接，注意风机马达须用工频电源，其接线应接在变频器的输入端。风机叶轮的正确旋转方向必须与风机机壳上的旋转方向箭头相一致。



注意：

- 1、防护等级比较高的马达（如户外使用），接线盒电缆与接头部分需用户做好防护，由于此处导致的马达接线盒进水，责任由客户自行承担。
- 2、马达停转时，在接线盒内仍可能带电，不要立即触摸接线柱。

13.2 接线指示图(标配):

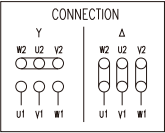
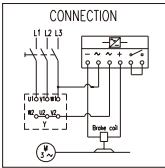
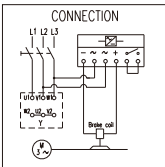
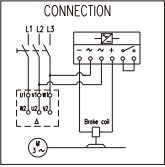
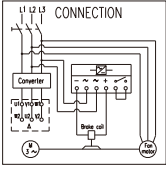
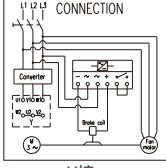
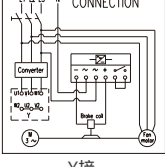
型号	接线指示图	适用范围
MU MH MP YZ	 <p>CONNECTION</p> <p>Y Δ</p> <p>W2 U2 V2 W2 U2 V2</p> <p>U1 V1 W1 U1 V1 W1</p>	适用于所有电压范围。
MU+Brake MH+Brake MP+Brake YZ+Brake	 <p>CONNECTION</p> <p>L1 L2 L3</p> <p>U1 V1 W1</p> <p>U2 V2 W2</p> <p>Y</p> <p>Brake coil</p> <p>M</p>	制动器外接交流电压220~240V。
MU+Brake MH+Brake MP+Brake YZ+Brake	 <p>CONNECTION</p> <p>L1 L2 L3</p> <p>U1 V1 W1</p> <p>U2 V2 W2</p> <p>Y</p> <p>Brake coil</p> <p>M</p>	制动器外接交流电压380~420V。
MU+Brake MH+Brake MP+Brake YZ+Brake	 <p>CONNECTION</p> <p>L1 L2 L3</p> <p>U1 V1 W1</p> <p>U2 V2 W2</p> <p>Δ</p> <p>Brake coil</p> <p>M</p>	制动器外接交流电压220~240V或380~420V。
MU+Brake +Fan MH+Brake+ Fan MP+Brake+ Fan YZ+Brake+ Fan	 <p>CONNECTION</p> <p>L1 L2 L3</p> <p>U1 V1 W1</p> <p>U2 V2 W2</p> <p>Δ</p> <p>Converter</p> <p>Brake coil</p> <p>M</p> <p>Fan motor</p>	制动器外接交流电压220~240V或380~420V。
MU+Brake +Fan MH+Brake+ Fan YZ+Brake+ Fan	 <p>CONNECTION</p> <p>L1 L2 L3</p> <p>U1 V1 W1</p> <p>U2 V2 W2</p> <p>Y</p> <p>Converter</p> <p>Brake coil</p> <p>M</p> <p>Fan motor</p>	制动器外接交流电压380~420V。
MU+Brake +Fan MH+Brake+ Fan MP+Brake+ Fan YZ+Brake+ Fan	 <p>CONNECTION</p> <p>L1 L2 L3 N</p> <p>U1 V1 W1</p> <p>U2 V2 W2</p> <p>Y</p> <p>Converter</p> <p>Brake coil</p> <p>M</p> <p>Fan motor</p>	制动器外接交流电压220~240V。

- ⚠ 注: a、以上所列风机均为三相风机,且风机电压频率跟马达一致。
 b、上表所列制动器接线均为较慢速制动控制方式,较快速制动,见下图例。
 c、上述接线图为我司标配,如有其它特殊需求,请另咨询。
 d、制动器的制动频次不应超过马达对应工作制及负载率允许的起停频次。

图例(快速制动):

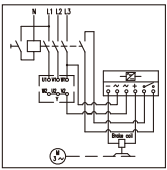
型号	接线指示图	适用范围
MU+Brake MH+Brake MP+Brake YZ+Brake	 <p style="text-align: center;">Y接</p>	制动器外接交流电压220~240V.

14 维护

14.1 概论

- ◆定期检修马达。
- ◆保持马达清洁，空气流通。
- ◆检查轴伸的密封圈，如有必要应及时更换。
- ◆检查安装连接状况和安装螺钉。
- ◆通过监听异常噪声，温度检测等来检查轴承运行情况。
- ◆如有异常发生，应立即停机，检查原因并及时排除。

14.2 轴承润滑

马达标配装有封闭式轴承，免维护。

14.3 制动器的维护

◆制动器气隙的调整

◎制动器的摩擦面经过长期使用后，将受到磨损，引起电磁铁与衔铁间的气隙增大和弹簧工作长度的增加，从而降低了弹簧压力，减少了制动力矩，同时由于气隙的增大，使衔铁吸合时电流值上升，严重时将使衔铁不能吸合，因此需经常检查气隙，进行调整或更换摩擦片。

◎气隙调整步骤如下：(参考图1)

- 取下风罩(7)。
- 取下防尘罩(5)。
- 调节气隙。
- 调整在下表所列范围内。

机座中心高	71	80	90	100	112	132	160	180	200	225	250	280
正常工作气隙(mm)	0.2	0.2	0.2	0.3	0.3	0.3	0.4	0.4	0.4	0.5	0.6	0.6
最大工作气隙(mm)	0.5	0.5	0.5	0.75	0.75	0.75	1	1	1	1.2	1.2	1.2

◆更换摩擦片

◎摩擦片属易损件，当摩擦片磨损超过下表数值时，就需要更换新的摩擦片：

机座中心高	71	80	90	100	112	132	160	180	200	225	250	280
最大磨损量(mm)	1.5	1.5	1.5	2.5	2.5	3.5	3.0	4.0	4.5	4.5	5.0	5.0

◎更换摩擦片步骤如下：

- 取下风罩(7)。
- 取下风扇(6)。
- 旋下螺栓(9)。
- 取下连接轴(8)。
- 取下防尘罩(5)。
- 将制动器线圈拆下。
- 取下制动盘，便可更换摩擦片。

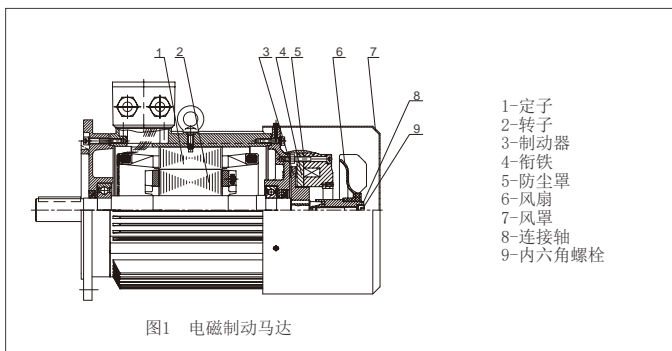

14.4 变频马达的维护特点

◆正常运行中的维护

用变频器对马达进行调速运转，由于变频器输出波形中含有的高次谐波的影响，马达噪音及振动比电网供电时的略大是正常的。随着运转频率的变化，基波分量、高次谐波分量在广范围内变化，与马达各部分及机械负载的谐振现象也增加，在调速到与系统谐振频率相一致的点时，机械系统将有大的振动和噪音。产生这种现象时，可采用增强系统刚度的方法来避免谐振，也可利用变频器的频率跳变功能，使与谐振点相当的输出频率向上或向下跳变，避开谐振频率，实现平滑运转。

◆附件的使用和维护

◎对于马达所带的光电编码器或测速机，请注意不应随意拆卸，并应避免碰撞。马达在搬动时，也不应以此处作为受力部位。安装与使用必须严格遵守编码器或测速机使用说明书的规定。

◎带有制动器的马达采用变频器驱动时，需要注意以下几点：

→马达所带的电磁制动器为失电制动型，通电后制动器即释放。制动器中磨擦盘内的间隙已在出厂前调整好，一般不宜随意变动。应严防油脂内物质和其它杂质进入磨擦盘，以确保制动器断电后制动器的可靠性。

→制动器电源不能接在变频器的输出侧，而一定要接在变频器的输入侧。

→由于制动作功量与转速的平方成正比，因此，高速时制动不应直接采用电磁制动器。而应利用变频器的再生制动功能，先将马达转速降低到工频转速以下，然后再进行电磁制动。

→如果变频器正在输出功率时制动器动作，将造成过电流切断。所以要在变频器主回路切断之后进行制动。

马达的常见故障与维护方法见下表

故障现象	造成故障的可能原因	处理方法
(1)不能起动	a. 定子绕组有一相开路	检查定子绕组，查出断路处，加以修复
	b. 定子绕组匝间及相间短路	测量定子绕组每相电阻和各相空载电流是否平衡，查出所在处，加包绝缘
	c. 定子接线错误	按铭牌上规定的接法和接线图，查出定子绕组的接线，纠正错误联接
	d. 负载或传动机械有故障	把马达和负载分开，如马达能正常起动，应检查被拖动机械，消除障碍
	e. 变频器参数设置不当	检查变频器参数，进行调整（变频马达）
	f. 制动器未动作	检查制动器及其电器（制动马达）
(2)变频马达起动后转速低于额定转速	a. 变频器的输出频率与输出电压设定不当	按使用要求重新设定
	b. 负载过重	检查负载传动装置是否正常
(3)马达有异常噪声或振动过大	a. 机械摩擦（包括定子相擦）	检查转动部分与静止部分间隙，找出相擦原因，进行校正
	b. 缺相运行	断电，再合闸，如不能起动，则可能有一相断电，检查电源或马达并加以修复
	c. 轴承缺油或损坏	清洗轴承，加新油。或更换新轴承
	d. 马达接线错误	查明原因，加以更正
	e. 修理后转子平衡被破坏	重新校动平衡
	f. 轴伸弯曲、变形	校直，必要时须更换转轴
	g. 联轴器俩连接松动	查清松动处，把螺栓拧紧
	h. 安装基础不平衡或有缺陷	检查基础固定情况，加以纠正
(4)马达温升过高	a. 过载	用电磁式电流表测量定子电流或检查变频器面板上的电流显示值（变频马达），发现过载时，应减轻负载
	b. 缺相运行	检查马达定子接线或变频器接线（变频马达），并加以修复
	c. 马达接法错误	Δ 接法马达误接成Y接工作或相反，必须立即断电改接
	d. 定子绕组接地或匝间或相间短路	检查找出短路和通地的部分，进行修复

故障现象	造成故障的可能原因	处理方法
(4)马达温升过高	e. 定、转子相擦	检查轴承装配有无松动，定子和转子装配有无不良情况，加以修复
	f. 通风不畅	检查风机和风叶有否损坏，风道有否阻塞。风机或风叶损坏应予以修复或更换。风道阻塞应移开妨碍通风的物件，清除风道污垢、灰尘及杂物，使空气流通
	g. 变频器的V、f参数设置不当，使马达低速轻载时出现过激励，电流大于额定值	调整V/f的参数设置（变频马达）
	h. 利用变频器的直流制动功能对马达进行制动时，制动电流太大	调整直流制动电流的设置，根据制动频繁程度，一般设置在额定电流的100%-150%。（变频马达）
	i. 制动器动作迟缓	检查制动器气隙和直流励磁电压（制动马达）
(5)轴承过热	a. 轴承损坏	更换轴承
	b. 轴承润滑脂过多、过少或有杂质	调整或更换润滑脂
	c. 轴承与轴、轴承与端盖配合过松或过紧	修整到合适的配合
	d. 马达两侧端盖或轴承盖没有装配好（不平行）	将两侧端盖或轴承盖止口装平，旋转螺栓
	e. 轴伸端油封安装不良	调整到合适的安装状态
(6)马达外壳带电	a. 接地不良	检查接地螺栓，接地线同机壳接触是否紧密
	b. 绕组受潮，绝缘电阻过低	绕组干燥处理
	c. 绝缘损坏，定子线圈碰铁芯	予以修复
	d. 接线板有污垢	清理接线板
	e. 引出线绝缘磨破	破损处用绝缘材料包扎
(7)马达在负载时不能起动	a. 定子绕组有匝间短路	检查各相电阻和各相电流
	b. 过载	检查马达负载电流
(8)三相电流不平衡	a. 匝间短路	修理绕组
	b. 接线错误	改正接线
	c. 三相电源电压不平	改善供电质量
(9)保险丝熔断	a. 两相间短路	修理绕组
	b. 负载过大	减小负载
	c. 电压过低	升高电压

故障现象	造成故障的可能原因	处理方法
(00) 绝缘电阻低或击穿	a. 绝缘老化或损伤	检修绝缘
	b. 不清洁	用干燥的压缩空气吹净内部
	c. 绕组或接线板受潮	拆开烘干或处理后再用
	d. 马达过热	拆开检修防止继续过热
(11) 制动马达制动失灵	a. 摩擦片磨损较大	调整气隙
	b. 弹簧失效	调换弹簧
	c. 动作迟缓	调整气隙，检查励磁电压
	d. 整流器损坏	调换整流器
	e. 制动线路故障	正确排除制动线路故障

注：



1. 用户想获得更详细的资料，请与本公司联系；
2. 无需通知，本公司保留对马达使用维护说明书的修改权。

售后服务

各种传动设备，客户发现有质量问题时，不要先拆卸零件，应说明以下情况然后与本公司售后服务部联系，说明现象后确认问题所在，再采用较理想的方法处理。

登录“www.boneng.com”

点击“服务”

点击“售后服务”

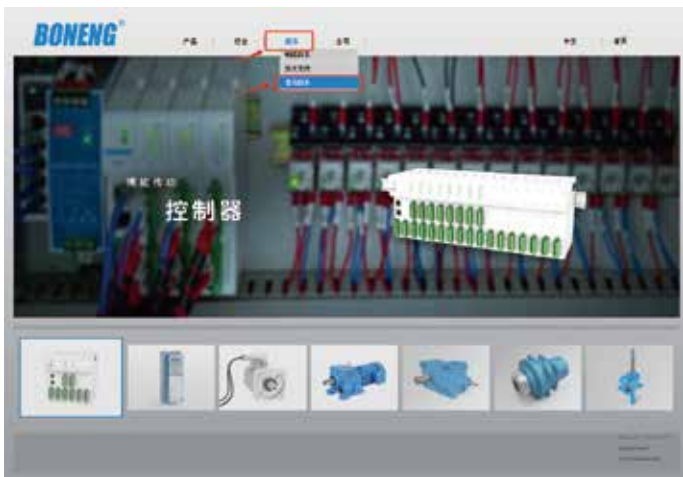

博能传动（沈阳）有限公司

控制器/驱动器：024-31271571

马达/齿轮马达/齿轮箱：024-31292571

博能传动（天津）有限公司

控制器/驱动器：022-86928559

马达/齿轮马达/齿轮箱：022-26929558

博能传动（开封）有限公司

控制器/驱动器：0371-23335230

马达/齿轮马达/齿轮箱：0371-23277771

博能传动（潍坊）有限公司

控制器/驱动器：0536-4699687

马达/齿轮马达/齿轮箱：0536-4699667

博能传动（长沙）有限公司

控制器/驱动器：0731-88386958

马达/齿轮马达/齿轮箱：0731-88380725

博能传动（苏州）有限公司

控制器/驱动器 苏南区：0512-66182005

马达/齿轮马达/齿轮箱 苏南区：0512-66189918

控制器/驱动器 浙沪区：0512-66182005

马达/齿轮马达/齿轮箱 浙沪区：0512-66189918

控制器/驱动器 苏皖区：0512-66182005

马达/齿轮马达/齿轮箱 苏皖区：025-52171612

博能传动（美国）有限公司

技术支持/调试/售后服务：

1250 E 222nd Euclid, OH 44117, United States

Email: America@boneng.com

Tel: 1-216-618-3099 / 1-216-618-0138

博能传动（印度）有限公司

技术支持/调试/售后服务：

Plot No. E-10/3, MIDC sinner (Malegaon) Industrial Area,
Nashik, 422123, Maharashtra, India.

Email: india@boneng.com

Tel: +91-11-4507 6293 / +91-22-2781 3385

其他地区

控制器/驱动器：0512-66182005

马达/齿轮马达/齿轮箱：0512-66189918

Contents

Important notes	35
1 Safety information	36
2 Technical information	36
2.1 The name plate information	36
2.2 Type designation	37
2.3 Noise level of gearmotor	39
2.4 Temperature rising	39
2.5 Notes (Following notes is related to the use of gearmotor)	40
3 Installation and dismantlement	41
3.1 Notes before installation	41
3.2 Preparations	41
3.3 Installation of gearmotor	41
3.4 Assembly of hollow shaft of gearmotor	43
3.5 Disassembly of hollow shaft of gearmotor	44
3.6 Torque arm assembly	45
3.7 Gearmotor input shaft connection with motor	46
3.8 Dismantlement of gearmotor	46
4 Mounting position	47
4.1 General description of mounting position	47
4.2 Specified description of mounting position	47
5 Lubrication/ Cooling/ Heating	54
5.1 Lubrication selection	54
5.2 Quantity of lubrication oil fill	54
5.3 Lubrication oil change	58
5.4 Heating	58
5.5 Backstop	58
6 Application	58
6.1 Fill the lubrication oil	58
6.2 Check the device	58
6.3 Start	58

7 Checks and maintenance	59
7.1 Check and maintenance regularly	59
7.2 Periods of checks and maintenance	59
7.3 Notes for checks and maintenance	59
8 Fault treatment	60
9 Overview	61
9.1 Instruction	61
9.2 Application scope of products	61
10 Common requirements	61
10.1 Starting	61
11 Instructions	63
11.1 Running environment	63
11.2 Safety factors	63
11.3 Conform to rules	63
12 Management	63
12.1 Storage	63
12.2 Transportation	63
13 Electrical connection	64
13.1 Overview	64
13.2 Wiring diagram	65
14 Maintenance	67
14.1 Overview	67
14.2 Bearing lubrication	67
14.3 Maintenance of brake	67
14.4 Maintenance characteristics of various frequency motor	69
15 After-sale service	73

Important notes

During installation, please pay attention to the safety notes and warning in this book!



Suggestions and useful information



Harmful situations:

Possible result: damage transmission device and the environment



If you conform to the regulations in this manual, there won't be any fault, at the same time, it can satisfy the requirements of quality defect claim. So before the transmission device starts working, please read this instruction;

This instruction book contains important installation and maintenance notes, please keep this instruction book in a place near the device for reference.

1 Safety information

Safety information mainly involve the applications of gearmotor. When running gearmotor, please note the relevant notes.

This instruction is an integral part of the gearmotor supplied.

All persons involved in the installation, operation, maintenance and repair of the gearmotor must have read the instructions and comply with them.

Conforming to the instruction strictly is a necessity for realizing non-fault running and performing any quality assurance requirement.

Under the premise of conforming to instruction, please pay attention to:

National (Local) regulations for relevant safety and accident preventions;

Special regulations and requirements of relevant devices;

Warning and safety mark on device.

The following situations will cause human injury and property loss:

Incorrect running;

Wrong installation or operation;

Disassemble the protect cover or housing against the instructions.

Any damage or stop caused by disregarding this instruction book will not be responsible by the company.

To seek for technical advance, we reserve the rights to modify the instructions. With continuous improvements, we will further improve its performance and safety performances on the foundation of keeping the basic characteristics.

2 Technical information

2.1 The name plate information

BONENG			
Type			
n ₂			RPM
P ₁	kW	T ₂	N · m
n ₁	RPM	i	
Oil		Wt.	kg
NO.		Date	

- Product type
- Output speed (only for directly connected motor)
- Rated input power kW (it means motor power for directly connected motor)
- Rated output torque N · m
- Rated input speed RPM (it means motor speed for directly connected motor)
- Nominal ratio
- Lubrication oil viscosity
- Weight
- Product number
- Production date

Data on nameplate are very important, please read them carefully and keep them clean. When services are needed, please provide the product number, used time and fault details.

2.2 Type designation

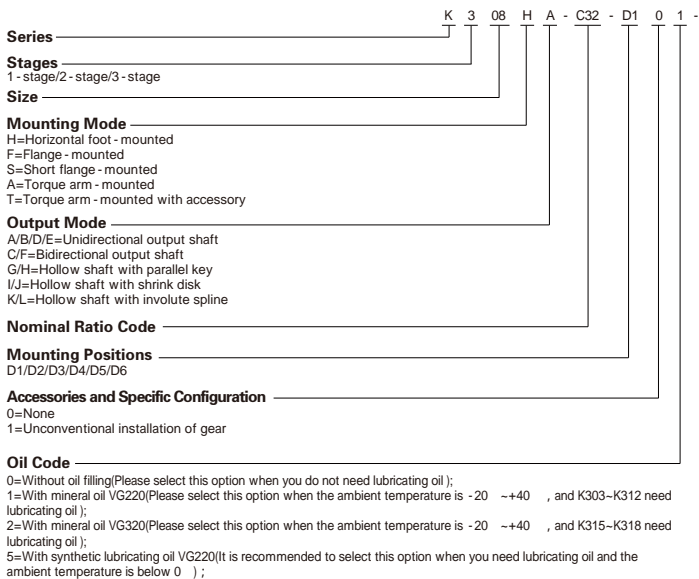

Note¹ Motor Type/Frame Size/Poles/Power Code

Power kW	MH/MP/MU	Power kW	MH/MP/MU	Power kW	MA	Power kW	MA
0.12	MH063M4A12AL MP063M4A12AL MU063M4A12AL	4	MH112L4B40AC MP112L4B40AC MU132S4B40AC	0.12	MA063M4A12AL	4	MA112L4B40AC
0.18	MH063M4A18AL MP063M4A18AL MU063M4A18AL	5.5	MH132S4B55AC MP132M4B55AC MU132M4B55AC	0.18	MA063M4A18AL	5.5	MA132L4B55AC
0.25	MH071M4A25AL MP071M4A25AL MU071M4A25AL	7.5	MH132M4B75AC MP132L4B75AC MU160M4B75AC	0.25	MA071M4A25AL	7.5	MA132L4B75AC
0.37	MH071M4A37AL MP071M4A37AL MU071M4A37AL	11	MH160S4C11AC MP160M4C11AC MU160L4C11AC	0.37	MA071M4A37AL	11	MA160M4C11AC
0.55	MH080M4A55AL MP080M4A55AL MU080M4A55AL	15	MH160M4C15AC MP160L4C15AC MU180M4C15AC	0.55	MA080M4A55AL	15	MA160L4C15AC
0.75	MH080M4A75AL MP080M4A75AL MU090S4A75AL	18.5	MH180M4C18AC MP180M4C18AC MU180L4C18AC	0.75	MA080M4A75AL	18.5	MA180M4C18AC
1.1	MH090S4B11AL MP090S4B11AL MU090L4B11AL	22	MH180L4C22AC MP180L4C22AC MU200L4C22AC	1.1	MA090M4B11AL	22	MA180L4C22AC
1.5	MH090S4B15AL MP090M4B15AL MU100L4B15AL	30	MH200M4C30AC MP200M4C30AC MU225S4C30AC	1.5	MA090M4B15AL	30	MA200M4C30AC
2.2	MH100M4B22AL MP100M4B22AL MU100L4B22AL	37	MH225M4C37AC MP225M4C37AC MU225M4C37AC	2.2	MA100M4B22AL	37	MA225M4C37AC
3	MH100M4B30AL MP100M4B30AL MU112M4B30AC	45	MH250M4C45AC MP225M4C45AC MU250M4C45AC	3	MA100M4B30AL	45	MA225M4C45AC
/	/	55	MH250M4C55AC MP250M4C55AC MU280S4C55AC	/	/	55	MA250M4C55AC
/	/	75	MH280S4C75AC MP280S4C75AC MU280M4C75AC	/	/	75	MA280S4C75AC
/	/	90	MH280M4C90AC MP280M4C90AC MU280M4C90AC	/	/	90	MA280M4C90AC

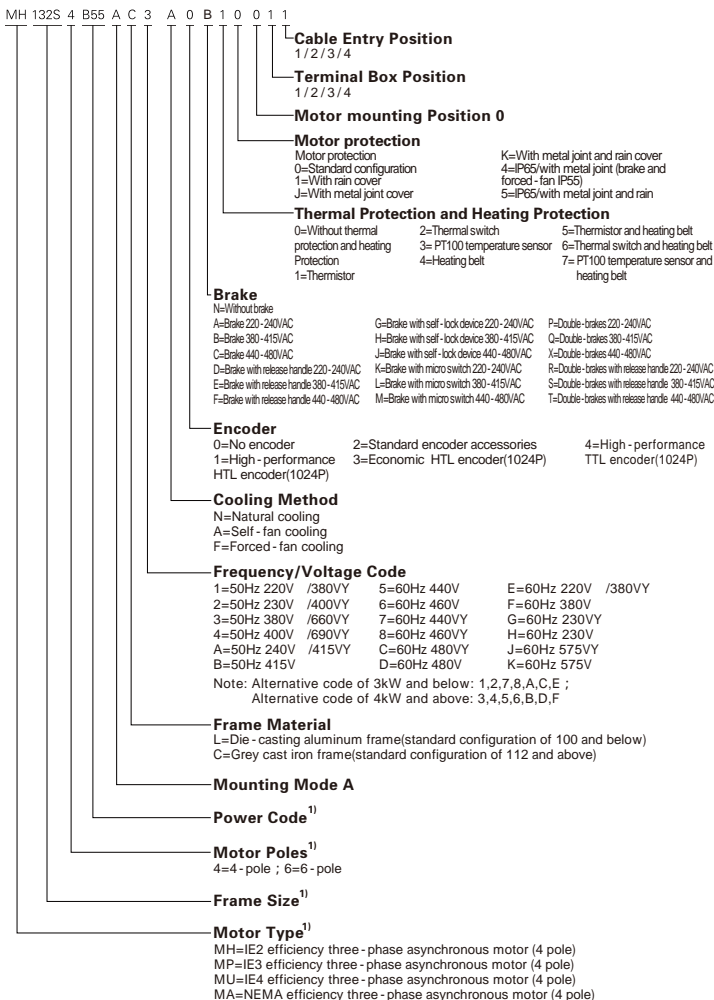

◆ Example of product type with input flange or input shaft: K308HA - C32 - D101 - AE3

◆ Example of product type with input flange and motor type: K308HA - C32 - D101 - AP132 - MH132S4B55FC3 - A0N10 - 011

◆ Combi-type designation: K308HA/C205 - D28 - D100 - MH080M4A75AL1 - A0N00 - 011

Note: MA type(NEMA efficiency three-phase asynchronous motor) alternative pole code 4, frequency and voltage code 6,8,G,H,J,K, brake code A,D,G,K.

2.3 Noise level of gearmotor

Noise level conforms to relevant national standard, industrial standard and enterprise standard.

Inspection of noise is done according to sound density theory, it is inspected in a distance of 1 meter (the surface noise region).

Noise level is tested when gearmotor is under good working situation with regulated rated input speed n_1 and rated input power p_1 stated on the name plate. If several figures are given, the highest speed and power values apply.

If the repeated measurement can't get the final result, you should apply the inspection result obtained from the test platform of our company.

A class noise power of gearmotor should not exceed 80dB(A).

2.4 Temperature rising

When the ambient temperature is 40℃, the running gearmotor oil temperature is not exceeded 85℃.

The allowable working temperature range of lubricating oil for gearmotor is roughly as follows:

Mineral oil is about -10℃ ~ +90℃ (Up to +100℃ at moment); Synthetic oil is about -20℃ ~ +100℃ (Up to +110℃ at moment)

2.5 Notes (Following notes is related to the use of gearmotor):

When installed outdoor, direct sunlight should be avoided, otherwise concentrated heat will affect the gearmotor performance.

The gearmotor must not be cleaned using high - pressure cleaning equipment.

All work such as inspection, maintenance and installation on gearmotor should be done when gearmotor is not in operation.

No welding work should be done on gearmotor, the gearmotor must not be used as an earthing point for welding work. Welding will cause irreparable damage to fine gear wheel and bearings.

If any changes are found during operation (for example, over heating or abnormal noise, etc), you should switch off driving device immediately.

All the rotating components should be equipped with protective cover to prevent accidental contact of staffs, such as couplings, hydraulic coupler, gear wheel, driving belt wheel, etc.

You should conform to the instructions on gearmotor, for example, nameplate, arrow of the direction, etc. These nameplates and marks must be kept free from dirt and paint out all times.

During assembly or disassembly work, the damaged bolts should be changed with new bolts with the same strength and category.

The bad results caused by unreasonable application of couplings, self - modification to gearmotor and application of the components of other companies are not included in " three - guarantee " services.

Depending on operation conditions of gearmotor, the surface, lubrication oil and components of gearmotor may reach high temperature, avoid being burnt.

When changing lubrication oil, take care to prevent scalding by hot oil.

Gearmotor should be laid on dry wooden foundation with no vibration and be covered well. When storing the gearmotor and any independent components, you should take anti - rust measures, avoid rusting, the gearmotor should not be piled together when stored.

Unless there are other regulations in ordering contract, gearmotor should not be stored or work in sites with strong acid, alkali, low temperature, high temperature and heavy polluted air, damp and the places with chemical articles.

When shifting the gearmotor, take care to avoid the shaft ends knocked, otherwise the gearmotor may be damaged. When lifting, don't use the front threads at the shaft ends to attach eyebolts for transport.

Spare parts must be purchased from BONENG.

3 Installation and dismantlement

3.1 Notes before installation



Confirm the gearmotor in good condition (no damage during transporting or storing).
Confirm site environment conforms to the name plate data. Standard working ambient temperature of gearmotor is -20 $-+40$, no oil, no acid, no harmful gas, no steam and radioactive substance etc.
When gearmotor is stored over 1 year, the lubrication life on bearings will be short.



Installing outdoor should avoid direct sunshine. In case of concentrated heat to influence smooth running of gearunit;
Special gearmotor: allocated according to ambient condition;
During planning period, you should reserve enough space to maintain or repair.

3.2 Preparations

Completely clean the preservative and pollutants, etc on the surface of input/output shaft and flange; be sure not to damage the oil sealing by solvents immersion;

Preparation of tools/materials: one group of spanner, torque spanner, assembly clamp tools, input and output fastening device, lubricant(anti-rust oil), medium of sealing bolts (thread locking adhesives).

3.3 Installation of gearmotor

The gearmotor foundation must be horizontal and level, no resonance vibrations, good rigid and anti-torque forces. When installing the drive transmission on position the rigid base frame, make adequately on consideration that the individual components cannot be changed even if putting the max load on.

Lift the gearmotor through the fasten bolt on the gearbox.



Note. Shaft end screw bolt is prohibited for the lifting fasten bolt.

Central height should be correctly aligned during foot-mounted ; coaxiality should be calibrated when coupling connect; run-out should keep within permissible values when flexible coupling while rigid coupling; contour and position tolerance should be guaranteed. And when long coupling, rigidity of shaft should be enough.

Gearmotor central height should be aligned when it is foot mounted :

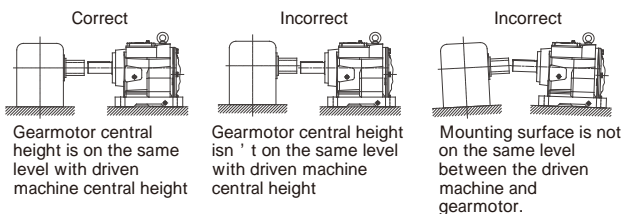

When installing the coupling, make absolutely certain that the following points are accurately aligned :

a) Axial misalignment

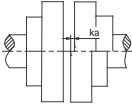

b) Angular misalignment

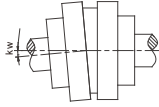

c) Radial misalignment

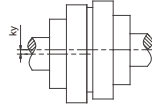

Flange - mount installation. Protruding (or concave) steps should inosculate with the housing:

Correct

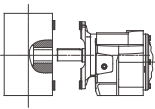

Connection parts should be coaxial.

Incorrect

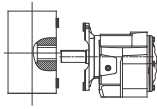

coupling is not coaxial with flange

Incorrect

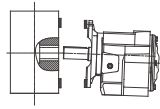

Flange mounting surface is not vertical with the connect shaft.

When gearmotor input or output is coupled with the couplings, belt pulleys, gear wheels and sprocket, must meet following requirement.

Press the drive components into the outer screw of output shaft, knock should be avoided.

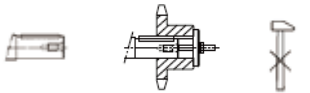

Correct

Incorrect

When using belt pulley, sprocket and pug mill, make consider the radial force. See the figure.

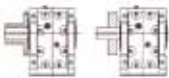

Correct

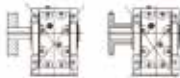

Incorrect

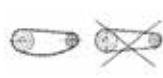

Correct

Incorrect

3.4 Assembly of hollow shaft of gearmotor

When hollow shaft is connected with solid shaft, clean and put anti-rust oil (hollow shaft must be exactly aligned with the machine shaft). Instead of the nut and threaded spindle shown in the diagram, other types of equipment such as a hydraulic lifting equipment can be used.

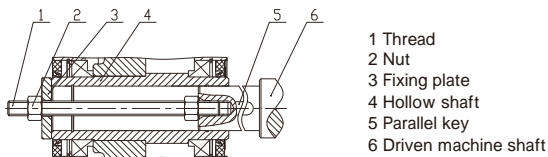

When hollow shaft of gearmotor is equipped with locking plate, you should first cover locking plate on hollow shaft, then finish the installation of driving shaft of driven device, you should not screw the fastening bolts on locking plate before installing the driving shaft of driven device.



- The locking plate being supplied can be directly installed, you can't tear it down before the first stress.
- Before installing locking plate, ensure the bore of hollow shaft and the machine shaft must be absolutely free of grease in the area of the shrink disk seat.

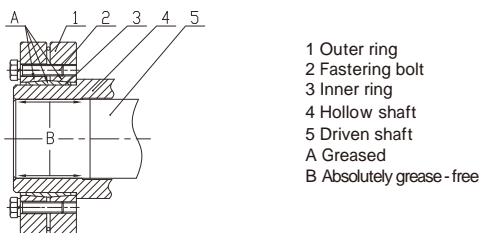

When screwing the bolts on locking plate, it is forbidden to screw it according to adjacent order, you should screw fastening bolts along with equilateral triangle order according to installation requirements of locking plate. During each circulated screwing process, each bolt can only screw 1/4 circle.

Generally fixing bolts adopt 8.8 level, in case of high temperature or vibration impact, please take anti-loosening measures on screw joints. The screw torque of each fastening bolt as follows.

Bolt size (mm)	Tighten torque (N • m)	Bolt size (mm)	Tighten torque (N • m)
M6	15	M30	2000
M8	36	M36	3560
M10	72	M42	5720
M12	123	M48	8640
M16	295	M56	13850
M20	580	M64	14300
M24	1000	M72	20800

3.5 Disassembly of hollow shaft of gearmotor

Disassembly of hollow shaft

Depending on the facilities available on site, the gearunit can be forced off the machine shaft using forcing screws in and end plate, a central threaded spindle or preferably a hydraulic lifting unit. Each end face of hollow shaft are equipped with 2 screw holes to screw in bolts used to fixing end plate.

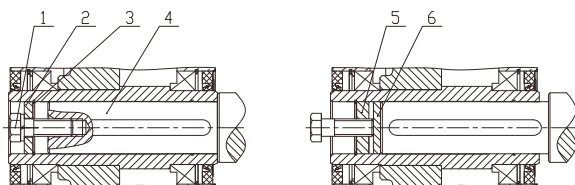

1. Bolt
2. Pressure plate
3. Circlip
4. Driven shaft

5. Nut
6. Assistant plate



Note:

The pressure plate and auxiliary plate are not in the range of delivery. (Arrangement and dimension of screw hole of hollow shaft end can refer to technical diagram of BONENG)



When disassembling the hollow shaft of gearmotor equipped with locking plate, the loosening of locking plate is reversed to fastening direction. Finish disassembly of driving shaft of driven device according to the above method after tearing down locking plate.

When disassembling locking plate, you should pay attention :

It is forbidden to loose bolts according to the adjacent order.

When outer ring of locking plate can't separate from inner ring, you can screw a few bolts into disassembly screw, separate inner ring from outer ring.

3.6 Torque arm assembly

Torque arm assembly , The hollow shaft must be exactly aligned with the machine shaft. Machine shaft swiveling and the gearmotor vibration shouldn't exceed the flexible range. Torque arm should be fixed and tightened.

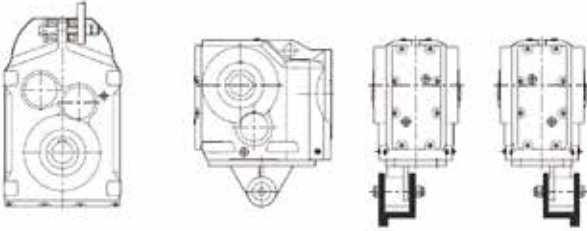

Torque arm B direction Torque arm A direction

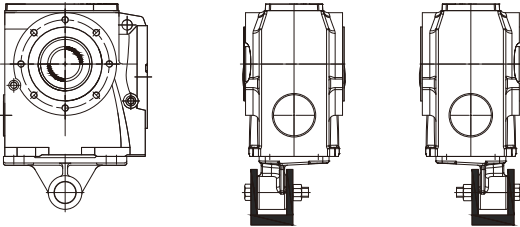

Torque arm B direction Torque arm A direction

3.7 Gearmotor input shaft connection (AE or AP) with motor

Clean the motor shaft, motor flange and coupling, remove the key on the motor shaft and change the new one. Heat the half of coupling to 100 °C, put it on motor shaft or AE solid shaft step position, fix the key and half of coupling with the tightening screw on motor shaft and AE shaft, connect the motor shaft with coupling device and make sure the two half of coupling is meshed well (see following figures). Flexible block can't be heated.

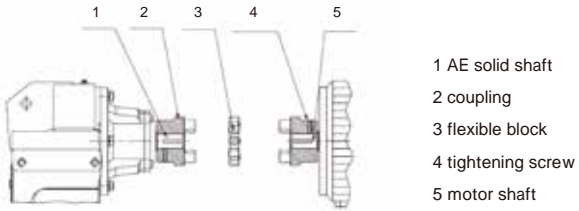

3.8 Dismantlement of gearmotor

Depending on the facilities available on site, the gearmotor can be forced off the machine shaft and please pay attention to protect the output shaft.





4 Mounting position

4.1 General description of mounting position

The mounting position details and type selection, please refer BONENG selection manual.

4.2 Specified description of mounting position

The symbol of mounting position and its meaning:

symbol		Meaning	
		Breather	Oil inlet
		Oil glass	
		Oil drain plug	

C Helical Gearmotor Mounting Positions C103H ~ C110H

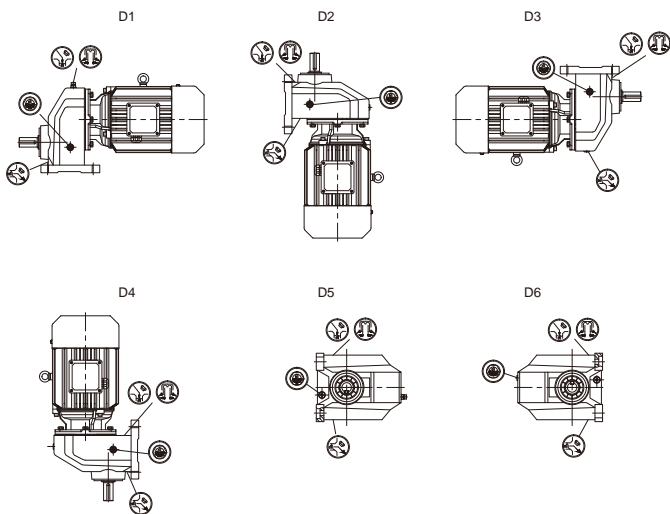

C103F ~ C110F

D1

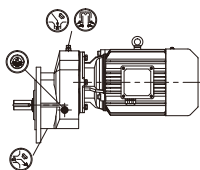

D2

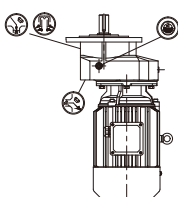

D3

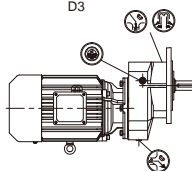

D4

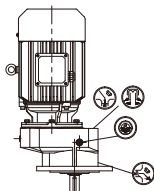

D5



D6



C203H ~ C216H
C303H ~ C316H

D1

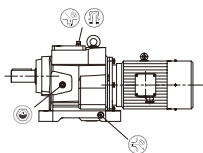

D2

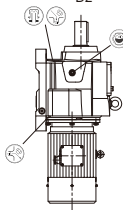

D3

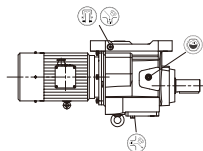

D4

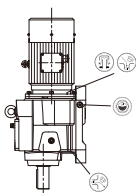

D5

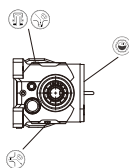

D6

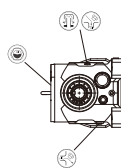

C203F/S ~ C216F/S
C303F/S ~ C316F/S

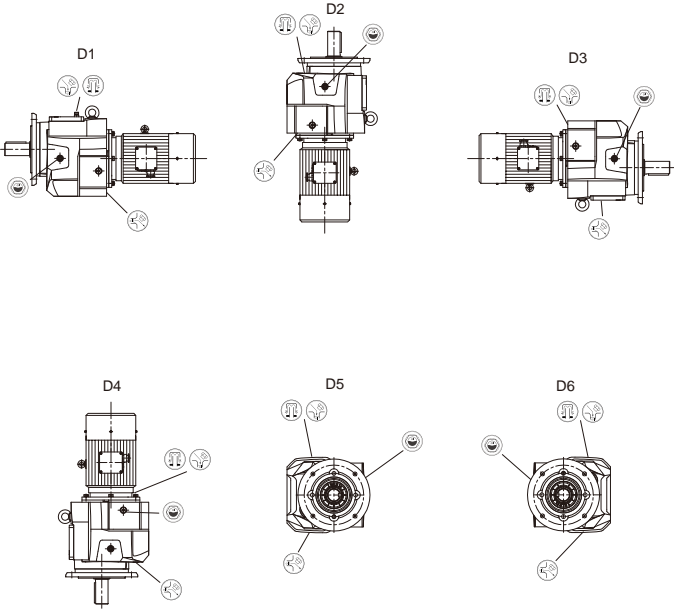

F202H/F/S/A/T ~ F215H/F/S/A/T
F302H/F/S/A/T ~ F315H/F/S/A/T

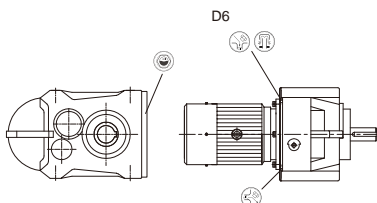
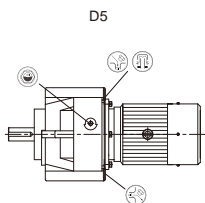
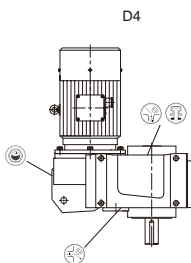
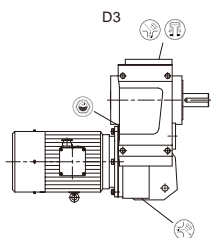
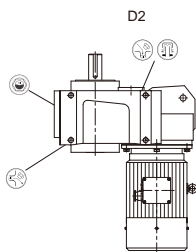
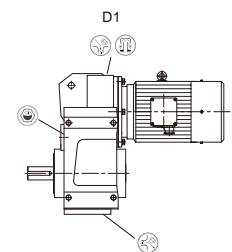

K Helical - Bevel Gearmotor Mounting Positions
K303H/F/S/A - K315H/F/S/A , K316H/F - K318H/F

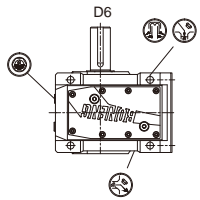
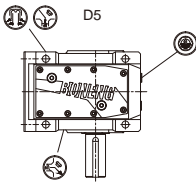
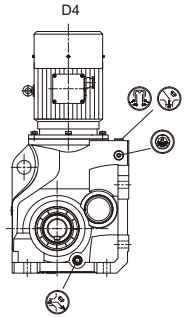
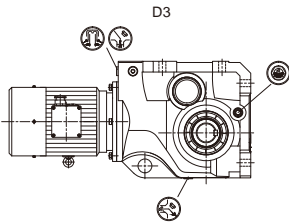
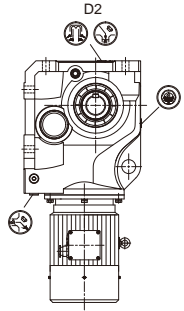
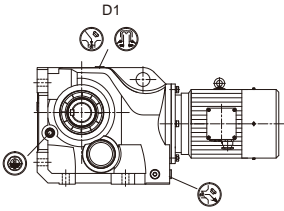

S helical - worm gearmotor mounting position
S103H/F/S/A - S209H/F/S/A , S210F/S/A - S212F/S/A

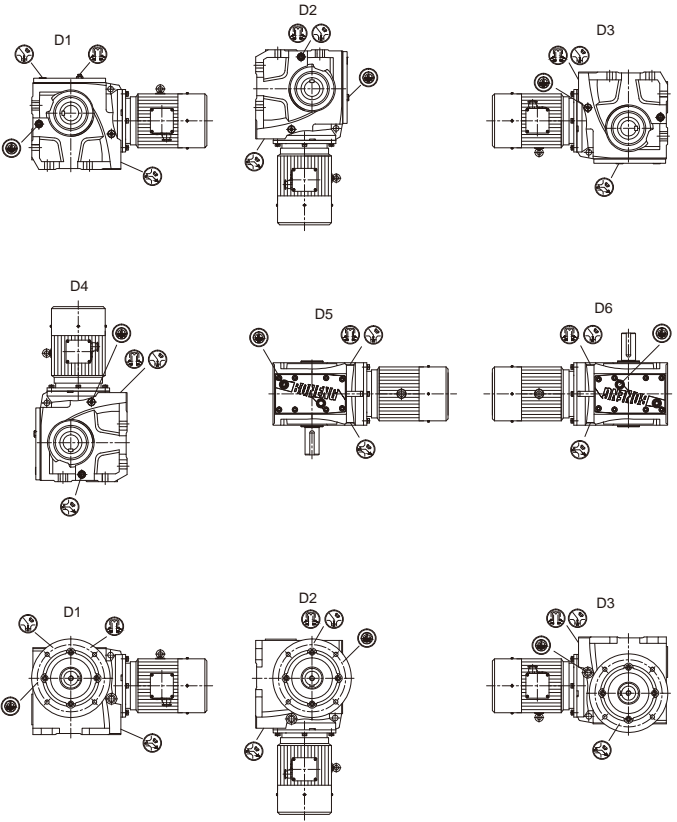

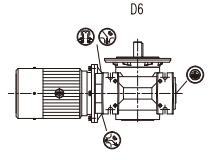
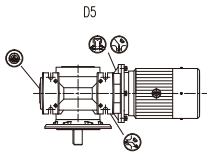
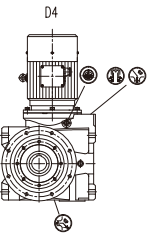
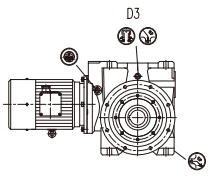
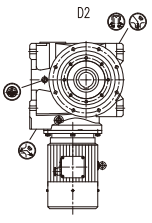
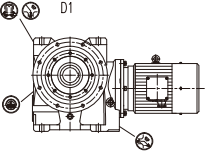
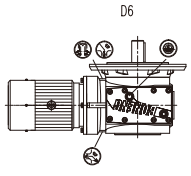
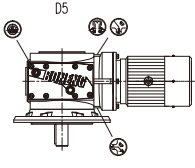
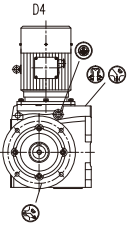

5 Lubrication/ Cooling/ Heating

5.1 Lubrication selection

Under the premise of the same viscosity level and category, you can choose internationally famous brand. If you need to change the recommended viscosity level, please consult.

Boneng lubrication oil selection are listed in following table

Type	Lubrication brand(adhesiveness of ISO)	Ambient temperature
C200/C201 C300/C301	000#	-20°C~+40°C
C103~C110	VG220	
C203~C216		
C303~C316		
F202~F215 F302~F315		
K303~K312		
K315~K318	VG320	
S203~S212	VG680	



When ambient temperature is lower than -10 , you have to use synthetic oil.

To ensure lifespan of the products, we recommend synthetic oil.

When ambient temperature exceeds the above range, please consult technical department of BONENG.

5.2 Quantity of lubrication oil fill

This quantity is a recommended value. According to the difference of gearmotor level and ratio, the oil filling quantity is different. Please pay attention to oil ruler scale as the indication of oil filling. Please refer the oil glass level and fill the oil to the middle level of oil glass.

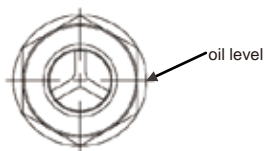

Following table lists the suggested oil value according to the gearmotor mounting position.

5.2.1 C series oil quantity (L)

Size \ Mounting position	D1	D2	D3	D4	D5	D6
C103	0.52	0.36	0.45	0.6	0.36	0.36
C104	0.7	0.45	0.6	0.8	0.45	0.45
C106	0.8	0.5	0.7	0.9	0.5	0.5
C107	1.6	1	1.6	2	1	1
C108	2.5	1.8	2.7	3.1	1.6	1.6
C109	3.5	2.5	3.7	4.3	2.2	2.2
C110	6.2	4.1	7.7	8.5	4.1	4.1
C200	0.2	0.2	0.2	0.3	0.2	0.2
C201	0.4	0.4	0.4	0.5	0.4	0.4
C301	0.4	1	1.1	1.2	0.9	1.1
C203	0.4	1	1.1	1.2	0.9	1.1
C303	0.4	1	1.1	1.2	0.9	1.1
C204	1	1.1	1.1	1.1	1.8	1.7
C304	1	1.1	1.1	1.1	1.8	1.7
C205	1.5	1.7	1.8	1.8	2.6	2.5
C305	1.5	1.7	1.8	1.8	2.6	2.5
C206	2	2.3	2.4	2.5	3.3	3.2
C306	2	2.3	2.4	2.5	3.3	3.2
C207	2	2.9	2.8	3.1	3.6	3.5
C307	2	2.9	2.8	3.1	3.6	3.5
C208	3.9	6.4	5.5	6	7.8	7.5
C308	3.9	6.4	5.5	6	7.8	7.5
C209	7.8	9.7	9.5	10.1	13.1	12.8
C309	7.8	9.7	9.5	10.1	13.1	12.8
C210	11	16.8	14.8	16.1	20	18.8
C310	11	16.8	14.8	16.1	20	18.8
C212	14.8	21.7	20.7	21.8	27	26.4
C312	14.8	21.7	20.7	21.8	27	26.4
C213	18.6	26.6	26.6	27.4	34	33.9
C313	18.6	26.6	26.6	27.4	34	33.9
C214	28.7	39	35.5	38.9	52	48.5
C314	28.7	39	35.5	38.9	52	48.5
C216	49.5	64	62	69	89	88
C316	49.5	64	62	69	89	88

5.2.2 F series oil quantity (L)

Size \ Mounting position	D1	D2	D3	D4	D5	D6
F202 F302	0.7	0.9	1	1	0.9	0.8
F203 F303	1.2	1.4	1.3	1.5	1.3	1.1
F204 F304	1.8	2.1	2.2	2.3	2.2	1.9
F205 F305	2.1	2.8	2.5	2.9	2.4	2.3
F206 F306	3.1	3.9	4.1	4.2	3.9	3.3
F207 F307	5.8	7.8	7.6	8.6	7.2	6.8
F208 F308	10.9	14.8	13.7	14.7	13.2	11.3
F209 F309	20	28	27	26	24	21
F210 F310	25	37	35	36	32	27
F212 F312	43	65	58	66	56	59
F215 F315	75	125	101	116	97	84

5.2.3 K series oil quantity (L)

Size \ Mounting position	D1	D2	D3	D4	D5	D6
K303	0.8	0.8	0.7	0.9	0.8	0.8
K304	1.2	1.1	1.2	1.6	1.3	1.3
K305	2.2	1.7	1.2	2.5	2.1	2.1
K306	2.2	1.6	1.6	2.6	1.9	1.9
K307	2.9	3.9	3.1	5.4	4.5	4.5
K308	5.2	6.6	8	10	8	8
K309	11	12	15	19	15	15
K310	17	21	25	33	25	24
K312	28	37	41	55	41	40
K315	50	61	68	90	72	71
K316	77	84	109	143	114	110
K318	103	113	155	202	158	158

5.2.4 S series oil quantity (L)

Oil quantity table (L)						
Mounting position Size	D01	D02	D03	D04	D05	D06
S203	0.3	0.5	0.6	0.7	0.5	0.5
S204	0.5	1.1	1.1	1.4	1.2	1.2
S205	0.6	1.4	1.2	1.9	1.7	1.7
S206	1.2	2.6	3.7	3.8	3.2	3.2
S207	2.3	5.0	7.0	7.8	5.9	5.9
S208	4.6	9.7	12.5	14.4	10.9	10.9
S209	8.9	18.0	22.6	28.3	21.6	21.6
S210	12.5	45.6	37.8	45.6	25.4	25.4
S212	22.0	80.4	63.6	80.4	42.8	42.8

Note: When ambient temperature is $-10 \sim +40$, for S series Products, lubricant brand is VG680 (Isoviscosity class).

5.3 Lubrication oil change

Change oil with the same type and manufactured in the same factory. Before filling the new oil, please clean the sediments, metal particles and remained oil in the housing off.

5.4 Heating

For standard gearmotor, the working ambient temperature is $-20 \sim +40$, when the temperature is under -10 , it needs to be preheated or running without load. When the gearmotor temperature is over -10 , gearmotor can be operated with load.

5.5 Backstop

Gearmotor with shrink disc. Before assembly or running, please check the transmission machine running direction. To avoid wrong direction running, if necessary, please consult technical person. Backstop do not need maintenance.

6 Application

6.1 Fill the lubrication oil

Our products are not filled with lubrication oil when delivered. You should fill lubrication oil according to instruction book before running.



On the position marked with this symbol, fill lubrication oil into gearmotor.

6.2 Check the device

Check oil level.

For the gearmotor equipped with backstop device, inspect whether wiring of motor is correct.

Inspect whether shaft sealing is effective.

Check whether the rotating components contact with other components.

6.3 Start

Check whether the running direction under free status is correct (supervise whether there is abnormal grinding noise when the shaft is running).

During running inspection, you should ensure no output component on shaft, open relevant supervision and protection device at the same time.

If there is abnormal running phenomenon (for example, temperature rise, noise, vibration, etc), you should turn off the motor and check out the reason.

Contact with BONENG when necessary.

7 Checks and maintenance

7.1 Check and maintenance regularly

Users should make regular maintenance to gearmotor.

Check the status of lubrication oil regularly, clean ventilation cap, fan, cooling coil and the surface of gearmotor, keep the gearmotor clean, ensure normal running of gearmotor.

7.2 Periods of checks and maintenance

Check oil temperature	Daily
Check abnormal noise of gearmotor	Daily
Check oil level	Monthly
Check gearmotor for leaks	Monthly
Check oil for water content	After working 400 hours, at least once a year
First oil change after starting	After working 400 hours
Subsequent oil changes	After every 5000 hours
Clean the breather	Every 3 months
Clean gearmotor housing	Do with oil changing
Check tightness of fastening bolts	The first time after changing oil, then change oil every two times
Carry out complete inspection of gearmotor	About every 2 years, do with oil changing

7.3 Notes for checks and maintenance:

Cut off power source, prevent electric shock, wait for cooling of gearmotor.

Inspection of oil level: Please refer the oil glass level and fill the oil to the middle level of oil glass .

Oil inspection: remove oil drain plug, take some samples, inspect oil viscosity index; if the oil is not clean, change it.

Oil changing:

It is forbidden to mix different lubricants.

After cooling, oil viscosity will increase, it is harder to drain off oil. change before cooling.

Put an oil picking plate under oil plug, tear down oil plugventilation cap, install oil plug after removing oil.

Inject new oil of the same brand, oil quantity should be the same with installation direction (see nameplate); if the brand number is different, consult after-sales department.

Inspect oil level at oil glass,install vent cap.

8 Fault treatment

Fault	Reason	Measure
Noise change of gearmotor	Fastening is loose	Tighten bolts/nuts to prescribed torque Replace damaged bolts/nuts
	Damage to gearmotor	Contact customer service →Check all teeth and replace any damaged parts
	Excessive bearing play	Contact customer service →Adjust bearing play
	Bearing defective	Contact customer service →Replace defective bearings
Operating temperature too high	Oil level in gearmotor housing too high or too low	Check oil level and, if necessary, adjust
	Oil too old	Contact customer service Check date of last oil change if necessary, change
	Oil badly contaminated	Contact customer service →Change oil
Increased vibration amplitudes at the bearing points	Bearing defective	Contact customer service →Check and, if necessary, replace bearings
	Gear defective	Contact customer service →Check gears and, if necessary replace
Oil leakage from gearmotor	Inadequate sealing of housing covers or joints	Check and, if necessary, replace seals, seal joints
	Radial shaft sealing rings defective	Contact customer service →Replace radial shaft sealing rings
Water in the oil	Oil foams in sump	Check state of oil by the test-tube method for water contamination. Have oil analysed by laboratory
	Gearmotor expose to cold air from machine-room ventilator	Protect gearmotor with suitable heat insulation. Close air outlet or alter its direction by structural measures

9 Overview

9.1 Instruction

This instruction book is a document provided with motor. It introduces starting, storage and installation requirements of motor and the notes, requirements, methods and notes for application and maintenance of motor. Maintainers should carefully read this instruction manual. Read nameplate, label, alarm signs on motor. Operators should pass relevant trainings before going to work.

△ Note:
To ensure safe and correct installation, operation and maintenance of device, please conform to relevant clauses in this instruction manual. Staffs responsible for installation or maintenance should pay attention to relevant instructions, the neglect of instruction will make quality assurance lose effect.

9.2 Applicable scope of products

This instruction book is appropriate for standard series and the derived series motors of Boneng (except anti - explosion motors).
Frame size central height: 56-280. (For the motors of special application sites or with special design, refer to other special instructions).

10 Common requirements

10.1 Starting

10.1.1 Reception inspection

After reception, check whether the motor has external damage, inspect all the nameplate data, especially the connection method of voltage and windings(Y or).

Spin running shaft with hand, check empty running situation of motor. If the motor is installed with locking device, open it.

For brake motor, connect power source, check whether the brake can be released, for brake with handle, pull the handle, check manual release performance.

10.1.2 Insulation performance inspection

Before first use of motor, windings may be affected with damp, measure the insulation resistance; for double winding various speed motor, measure insulation resistance of the two groups of windings.

△ Note: After measurements, winding should discharge electricity immediately, avoiding electric shock.

Winding should be remade when immersed in seawater.

10.1.3 Direct start, Y/ Δ start and various frequency start

Wiring box of standard single speed motor usually has 6 wiring bolts and at least 1 grounding bolt.

Before the motor is connected with power, it should be reliably grounded according to regulations, zero connecting can't replace grounding.

Connection method of voltage and winding are marked on nameplate.

Direct start

Winding can apply Y or Δ connection method, for example, 660VY, 380V Δ express 660V, Y connection method and 380V, Δ connection method.

Y/ Δ start

- Power source voltage should be equal to rated voltage of wiring motor.
- Tear down all the wiring pieces on wiring plate, install wiring according to Y/ Δ starting, connect it to six wiring columns of motor, it can trip from Y connection of initial period of starting to Δ connection with completed starting.
- The power source connection of double speed motor and other special motors should be done according to the wiring diagram in wiring box.

Various frequency start

- Make correct wiring to frequency changer according to instruction manual of frequency changer, make inspection before charging. After inspection, first not connect motor, set and adjust parameters of frequency changer. After confirming that there is no problem for frequency changer running, connect motor.
- After giving out "connection" order, if the motor doesn't rotate, please first check the frequency changer, whether output frequency has been set; If the motor doesn't run, please check wiring and loading situation of motor.
- Before the motor (cooling method to IC416) starts, start fan and ensure it runs well, pay attention to motor, transmission device, production machinery and displayed data of frequency changer panel. If there is any abnormal situation, stop the machine immediately, check out the fault and remove the fault, then restart.

10.1.4 Wiring column and rotation direction

Observing rotation shaft from motor driving terminals, the rotation is in clockwise direction.

Switching any two phases of power cable can change running direction of motors.

11. Instructions

11.1 Running environment

Motor is used for industrial production.

Normal ambient temperature is between -15 and 40 , the altitude is not higher than 1000m.

11.2 Safety factors

The motor should be installed and wired by specialists who are familiar with relevant safety requirements.

During installation, there should be safety device to prevent accidents, the position should conform to regulations.

11.3 Conform to rules

The motor can't be used for acceleration and overloading running.

Motors with special design considerations should be indicated.

12. Management

12.1 Storage

All the motors should be stored indoor, the environment should be dry, with no vibration and dust.

Motor surface (shaft extension end and flange) with no protective layer should take anti-rust measures.

It is suggested to check motor regularly, turn running shaft with hand, prevent lubrication grease loss or other problems.

If it is installed with anti-condensation heater, better apply.

12.2 Transportation

The motor needs to install the lock device in transportation.

13. Electrical connection

13.1 Overview:

The wiring box at the top of motor can be rotated, select outlet direction according to requirements. You can also select wiring box installation method of side outlet wire.

The inlet port with no cable should be sealed.

Except the wiring of main winding and grounding end, the wiring box has thermistor, heating zone, thermoswitch or PT100 resistive element and wiring parts of brake in wiring box.

For motors with magnetic brake, when customers provide power source by themselves, ensure motor power by switched together with brake power source.

Frequency-changing motor with cooling method IC416 should be installed with axial flow fan. Axial flow fan is equipped with special wiring box. Fan motor should be connected with relevant power source voltage. Fan motor should apply non-reversible frequency power source, the wiring should be on input end of frequency changer. The correct running direction of fan blade should be the same with the running direction arrow on fan cover.

△ Note:

1. For motors (if used outdoor) with high protection level, wiring box cable and joint should make protections. If motor wiring box has water inside, the responsibility will be borne by customers.
2. When motor stops running, the wiring box may be with electricity, don't touch wiring column.

13.2 Wiring diagram (standard configuration)

Type	Wiring diagram	Applicable scope
MU MH MP YZ	<p>CONNECTION</p> <p>Y Δ</p> <p>W2 U2 V2 W2 U2 V2</p> <p>U1 V1 W1 U1 V1 W1</p>	Applicable to all voltage range.
MU+Brake MH+Brake MP+Brake YZ+Brake	<p>CONNECTION</p> <p>L1 L2 L3</p> <p>U1 V1 W1</p> <p>Brake coil</p> <p>Y</p> <p>Y соединение</p>	Brake with external AC voltage 220~240V.
MU+Brake MH+Brake MP+Brake YZ+Brake	<p>CONNECTION</p> <p>L1 L2 L3</p> <p>U1 V1 W1</p> <p>Brake coil</p> <p>Y</p> <p>Y соединение</p>	Brake with external AC voltage 380~420V.
MU+Brake MH+Brake MP+Brake YZ+Brake	<p>CONNECTION</p> <p>L1 L2 L3</p> <p>U1 V1 W1</p> <p>Brake coil</p> <p>Δ</p> <p>соединение</p>	Brake with external AC voltage 220~240V or 380~420V.
MU+Brake +Fan MH+Brake+ Fan MP+Brake+ Fan YZ+Brake+ Fan	<p>CONNECTION</p> <p>L1 L2 L3</p> <p>U1 V1 W1</p> <p>Brake coil</p> <p>Y</p> <p>соединение</p>	Brake with external AC voltage 220~240V or 380~420V.
MU+Brake +Fan MH+Brake+ Fan MP+Brake+ Fan YZ+Brake+ Fan	<p>CONNECTION</p> <p>L1 L2 L3</p> <p>U1 V1 W1</p> <p>Brake coil</p> <p>Y</p> <p>Y соединение</p>	Brake with external AC voltage 380~420V.
MU+Brake +Fan MH+Brake+ Fan MP+Brake+ Fan YZ+Brake+ Fan	<p>CONNECTION</p> <p>L1 L2 L3 N</p> <p>U1 V1 W1</p> <p>Brake coil</p> <p>Y</p> <p>Y соединение</p>	Brake with external AC voltage 220~240V.



Note:

- a. The above listed fans are three-phase fan, fan voltage frequency is the same with motor.
- b. The brake wiring applies slow speed wiring control method. More rapid braking, see illustration below.
- c. The wiring diagram above is standard configuration, any other special requirement should be referred to us.
- d. The brake frequency should not exceed the corresponding operation system of electric motor and the on and off frequency allowed by the load rate

Legend (Fast braking) :

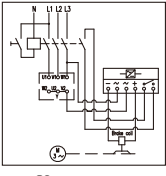
Type	Wiring diagram	Applicable scope
MU+Brake MH+Brake MP+Brake YZ+Brake	 <p style="text-align: center;">Y соединение</p>	Brake with external AC voltage 220~240V.

14. Maintenance

14.1 Overview

Check motor regularly.

Keep motor clean, air flow.

Check sealing ring of shaft extension, change in time when necessary.

Check installation and connection situation, mounting bolts.

Check bearing running situation by listening to abnormal noise, temperature detection, etc.

If there is abnormal situations, stop the machine immediately, check out the reason, remove the problem in time.

14.2 Bearing lubrication

Standard motor is fitted with seal type bearing and free maintenance.

14.3 Maintenance of brake

Adjustment of brake air gap

After long - term application of abrasion face of brake, it will be damaged, increasing air gap between electromagnetic iron and armature and the spring working length, thus reducing spring pressure and brake torque, at the same time, as the increasing of air gap, current rises when armature pulls in, when the situation is serious, armature will not be pulled in. So you should often check air gap, adjust it or change abrasion piece.

Air gap adjustment procedure is as follows: (reference Fig. 1)

Take wind cover down(7).

Remove the dust cover(5).

Adjust the air gap.

Adjust the range listed in table below.

Central height of frame size	71	80	90	100	112	132	160	180	200	225	250	280
Normal working air gap(mm)	0.2	0.2	0.2	0.3	0.3	0.3	0.4	0.4	0.4	0.5	0.6	0.6
Maximum working air gap(mm)	0.5	0.5	0.5	0.75	0.75	0.75	1	1	1	1.2	1.2	1.2

Change friction disc

Friction disc is easy to be damaged, when friction of the disc exceeds the following value, change a new one

Central height of frame size	71	80	90	100	112	132	160	180	200	225	250	280
Maximum friction quantity (mm)	1.5	1.5	1.5	2.5	2.5	3.5	3.0	4.0	4.5	4.5	5.0	5.0

The procedure of changing friction disc:

Take down wind cover(7).

Take down fan(6).

Screw down bolt(9).

Remove the connecting shaft(8).

Remove the dust cover(5).

Tear down lead wire of brake coil.

Tear down brake disc, change friction disc.

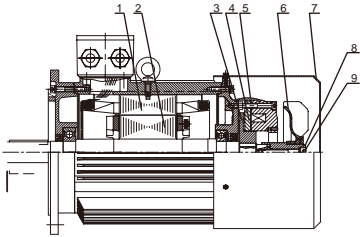

- 1-Stator
- 2-Rotor
- 3-Brake
- 4-Armature
- 5-Dust cover
- 6-Fan
- 7-Wind cover
- 8-The connecting shaft
- 9-Socket head bolts

Fig. 1 Electromagnetic brake motor

14.4 Maintenance characteristics of various frequency motor

Maintenance during normal running

Adjust the speed of motor with frequency changer. As there is higher harmonic influence in frequency -changer output wave, motor noise and vibration are larger than the situation during mains supply, there is normal. When the change of running frequency, fundamental component, higher harmonic component change in a large scope, the resonance with each part of motor and mechanical loading are increasing, when adjusting to the point the same with system resonance frequency, mechanical system will has large vibration and noise. When there is such kind of phenomenon, you can apply the method of increasing system rigidity to avoid resonance, or you can make the output frequency equal to resonance point jump upward or downward by frequency jumping function of frequency changer, avoid resonance frequency, realize smooth running.

Application and maintenance of accessories

- ◎ Photoelectric encoder or speed - measuring machine brought with motor should not be torn down, avoid collision. When the motor is moved, this part should not be used as stressed part. Installation and application should strictly conform to regulations of encoder or speed - measurement machine.
- ◎ When motor with brake applies frequency - changer driving, pay attention to the following points:

Electro magnetic brake of motor is power - off type brake and released after power - on. the clearance of brake pads has been well adjusted before delivery and no changes should be made arbitrarily. Oil grease substance and other impurities should be prevented from entering into brake pads to ensure the reliability of brake in case of power - off.

Brake power source should not be connected on output side of frequency changer, it should be connected in input side of frequency changer.

As brake work is proportional to quadratic running speed, so high speed brake should not apply electromagnetic brake directly. Reduce motor speed under frequency speed with the regeneration brake function of frequency changer, then make electromagnetic brake.

If brake moves when frequency changer is outputting power, the current will be cut off. Brake should be done after main return circuit of frequency changer is cut off.

Common fault and maintenance method of motor

Fault	Possible reasons of fault	Treatment
(1) Can't start	One phase of stator windings is open - circuited	Check stator winding, check the shortcut part, repair
	Phase or interturn of stator windings is short - circuited	Measure whether stator winding resistance and no - load current of each phase are balanced, checkout the position, with insulation
	Stator wiring error	Check out stator winding wire according to the regulated connection method on nameplate and the wiring diagram, correct wrong connection
	Loading or transmission machinery have faults	Separate motor from loading, if the motor can start normally, check the machinery being pulled, remove faults.
	Frequency - changer parameter setting is not appropriate	Check frequency changer parameters, adjust (frequency changer motor)
	Brake doesn ' t work	Check brake and the machine (brake motor)
(2) After frequency changer motor starts, speed is lower than rated speed	Output frequency and output voltage setting of frequency changer are not appropriate	Reset according to application requirements
	Loading is too heavy	Check whether loading transmission device is normal
(3) Motor has abnormal noise or the vibration is too large	Mechanical friction (including stator and rotor phase friction)	Check the distance between transmission part and the static part, check out phase friction reason, correct
	Phase - lack running	Cut off electricity, switch on, if it can ' t start, maybe one phase cuts electricity, check the power source or motor to repair
	Bearing lacks oil or is damaged	Clean bearing, add new oil, or change new bearing
	Motor wiring is wrong	Check out the reason, correct
	Balancing of rotor after repair is damaged	Re - correct balancing
	Shaft extension bends, transforms	Correct, change running shaft when necessary
	Coupling connections loose	Check out the loosing part, screw down bolts
	Installation foundation is not balanced or has defects	Check foundation fixing situation, correct
(4) Motor temperature rise is too high	Overload	Measure stator current of electromagnetic current table or check the current display value on frequency changer panel (frequency - changer motor), if it is overloaded, reduce loading.
	Phase - lacking running	Check motor stator wiring or frequency changer wiring (frequency changer motor), and repair
	Motor wiring is wrong	- connection wiring of motor is connected incorrectly in Y or vice versa, cut off power source to change connection
	Stator winding grounding or interturn or phase - to - phase short circuit	Check out short circuit and grounding part, repair

Fault	Possible reasons of fault	Treatment
(4) Motor temperature rise is too high	Stator, rotor frictions	Check whether bearing assembly loose, whether stator and rotor assembly are bad, repair
	Ventilation is not good	Check whether fan and blade are damaged, whether wind path is blocked. If fan or blade is damaged, repair or change. If the wind path blocks, remove the articles that obstructs ventilation, clean wind path dirt, dust and impurities, make air flow smoothly
	V,F parameter settings of frequency changer are not appropriate, there will be over excitation when motor is under low speed and light loading running, the current is larger than rated value	Adjust parameter setting of V/f (frequency changer motor)
	When braking the motor with DC brake function of frequency changer, brake current is too large	Adjust DC brake current setting, according to brake frequency, set it to be 100% - 150% of rated current.
	Brake action is slow	Check brake air gap and DC excitation voltage (brake motor)
(5) Bearing is overheat	The bearing is damaged	Change bearing
	Bearing has too much or too less lubrication grease, or with impurities	Adjust or change lubrication grease
	The mating of bearing with shaft, bearing or end cover is too loose or too tight	Repair to appropriate allocation
	Side end cover or bearing cover of motor are not assembled well (not paralleled)	Make side end cover or bearing cover seam horizontal, rotate bolts
	Shaft extension oil sealing is not installed well	Adjust to appropriate installation status
(6) Motor cover has electricity	Grounding is not good	Check grounding bolt, whether grounding wire has tight connection with machine cover
	Winding damps, insulation resistance is too low	Winding drying treatment
	Insulation is damaged, stator coil collides with iron core	Repair
	Wiring plate has dirt	Clean wiring plate
	Outlet insulation is damaged	Pack the damaged parts with insulation materials

Fault	Possible reasons of fault	Treatment
(7)Motor can ' t start with loading	Rotor winding has interturn shortcircuit	Check resistance and current of each phase
	Overload	Check motor loading current
(8)Three - phase current is not balanced	Interturn shortcircuit	Repair winding
	Wiring is wrong	Correct wiring
	Three - phase power source and voltage are not balanced	Improve electricity supply quality
(9)Fuse cuts	The two phase has shortcircuit	Repair winding
	Loading is too large	Reduce loading
	Voltage is too low	Rise voltage
(10)Insulation resistance is too low or be broken down	Insulation aging or damaged	Repair insulation
	Not clean	Blow the inner part with dry compressed air
	Winding or wiring plate damps	Tear down to dry or reuse after treatment
	Motor is overheat	Tear down inspection, prevent continuous heating
(11)Brake motor brake loses effect	Friction disc is seriously abraded	Adjust air gap
	Spring loses effect	Change spring
	Action is slow	Adjust air gap, check excitation voltage
	Rectifier is damaged	Adjust rectifier
	Brake wire path has fault	Remove brake wire fault correctly



Note:

1. Customers want to obtain detailed data, please contact with us.
2. We have the right to modify the maintenance manual without notice.

After-sale service

For the various kinds of transmission devices, if there is any quality problem, don't tear down components, you should illustrate the situation, then contact with after-sales department of the company, confirm about the problems, then apply ideal method to deal with them.

Logging in " www.boneng.com "

Click " Service "

Click " After - sale Service "



BONENG TRANSMISSION(SHEN YANG)CO.,LTD

Controller/Drive : 024 - 31271571

Motor/Gear motor/Gearbox : 024 - 31292571

BONENG TRANSMISSION(TIAN JIN)CO.,LTD

Controller/Drive : 022 - 86928559

Motor/Gear motor/Gearbox : 022 - 26929558

BONENG TRANSMISSION(KAIFENG)CO.,LTD

Controller/Drive : 0371 - 23335230

Motor/Gear motor/Gearbox : 0371 - 23277771

BONENG TRANSMISSION(WEIFANG)CO.,LTD

Controller/Drive : 0536 - 4699687

Motor/Gear motor/Gearbox : 0536 - 4699667

BONENG TRANSMISSION(CHANGSHA)CO.,LTD

Controller/Drive : 0731 - 88386958

Motor/Gear motor/Gearbox : 0731 - 88380725

BONENG TRANSMISSION(SUZHOU)CO.,LTD

Controller/Drive Southern Jiangsu : 0512 - 66182005

Motor/Gear motor/Gearbox Southern Jiangsu : 0512 - 66189918

Controller/Drive Zhejiang - Shanghai : 0512 - 66182005

Motor/Gear motor/Gearbox Zhejiang - Shanghai : 0512 - 66189918

Controller/Drive Jiangsu - Anhui District : 0512 - 66182005

Motor/Gear motor/Gearbox Jiangsu - Anhui : 025 - 52171612

BONENG TRANSMISSION(USA/Canada)CO.,LTD

Technical Support/Debugging/After - Sales Service :

1250 E 222nd Euclid, OH 44117, United States

Email: America@boneng.com

Office Tel: 1 - 216 - 618 - 3099 / 1 - 216 - 618 - 0138

BONENG TRANSMISSION(India)CO.,LTD

Technical Support/Debugging/After - Sales Service :

Plot No. E - 10/3, MIDC sinner (Malegaon) Industrial Area,

Nashik, 422123, Maharashtra, India.

Email: india@boneng.com

Tel: +91 - 22 - 2781 3385 / +91 - 11 - 4507 6293

Other District

Controller/Drive : 0512 - 66182005

Motor/Gear motor/Gearbox : 0512 - 66189918

BONENG